

FLS-50 FLOW SENSOR

Properties

- To be used for break-monitoring of internally cooled tools
- Suitable for different flowrate measuring ranges
- Degree of protection IP65
- Compact design
- Simple installation

The flow sensor FLS-50 suits rough industrial conditions and is employed in combination with all ARTIS tool and process monitoring systems.

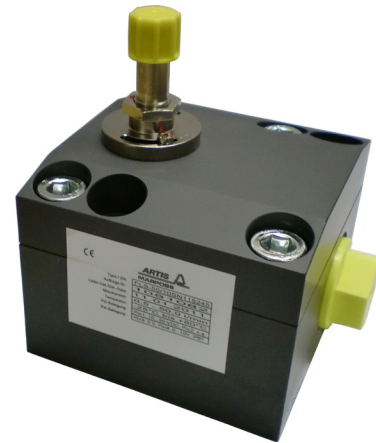

Illustration similar

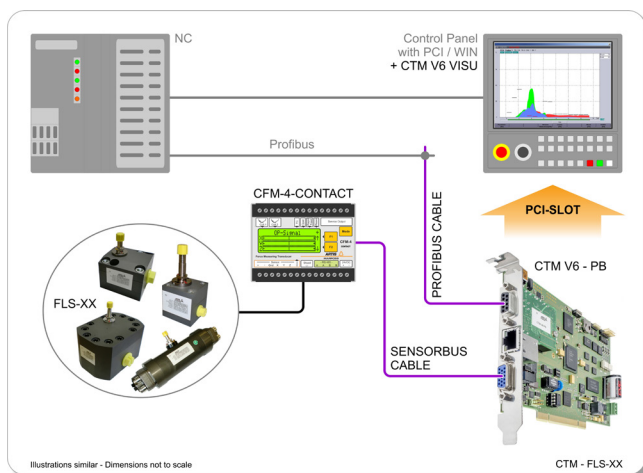
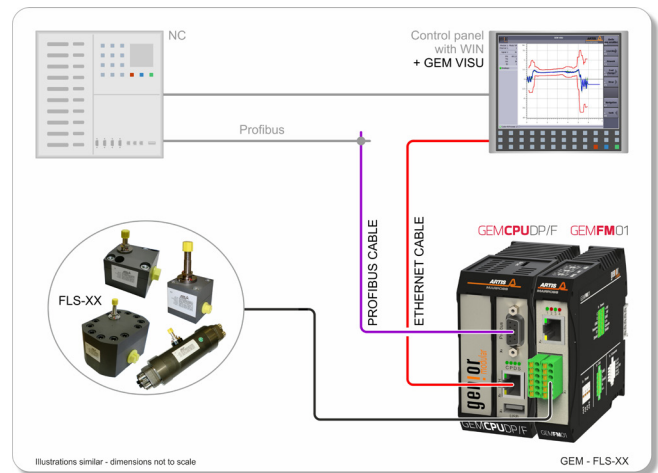
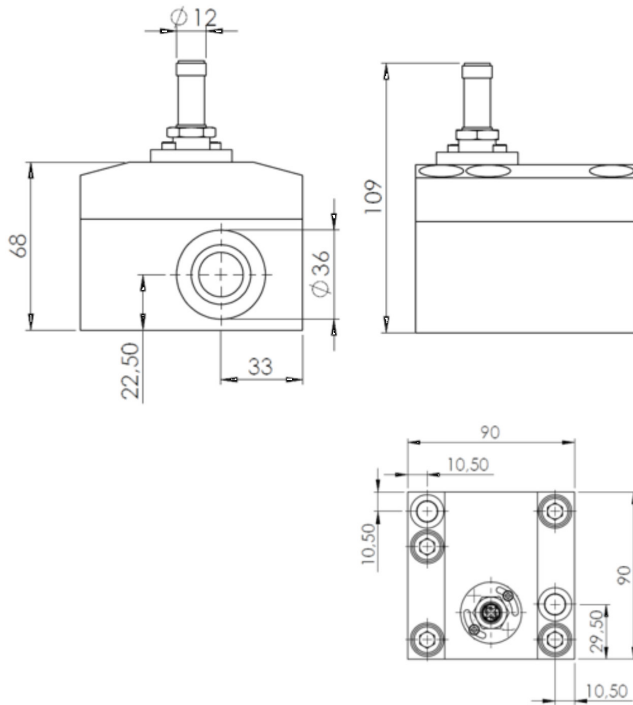

Illustration similar



Application example:
FLS Flow Sensors with CFM-4 CONTACT Universal Measuring Transducer in the CTM Tool and Process Monitoring System.

Application example:
FLS Flow Sensors with GEMFM01 Force Measuring Transducer in the GENOR MODULAR Tool and Process Monitoring System.



Electrical connection diagram

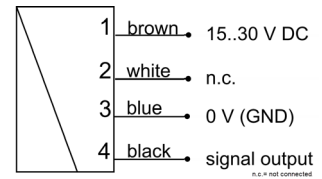

connection example



FLS-50	
CODE	O3PZ1211003

DIMENSIONS	90 mm x 90 mm x 109 mm
MATERIAL	Aluminium, anodized
WEIGHT	1.6 kg
THREADED CONNECTION	G 3/4"
DEGREE OF PROTECTION	IP65
OPERATING TEMPERATURE	-0 °C ... +70 °C
ELECTRICAL CONNECTION	For round connectors M 12x1, 4 poles, 10 m connecting cable (incl. connector)
VOLTAGE SUPPLY	15 – 30 V
VOLTAGE OUTPUT	0 – 10 V
CHARGING RATE	< 20 mA (without load)

MAX. PRESSURE	200 bar
MEASURING RANGE	0.5 – 50 l/min
FREQUENCY	2.0 cm ³ = 1 pulse max. 417 Hz at 50 l/min
ACCURACY	3 % of measured value (measured at flow rate or 20 mm ² /s)
REPEATABILITY	± 0.3%
USABILITY	Viscous fluid, self-lubricating media (technical soaps, pastes and non abrasive emulsions)
FILTER RANGE	< 30 µm
CONFORMITY	CE, UKCA



Important notice!

Dirt particles must not get into the flow chamber, as this might cause the blockage of the gearwheels. It may therefore be necessary to install filters upstream of the sensor (mesh size < 30 µm).



www.marposs.com

For a full list of address locations, please consult the Marposs official website

ODN6406EN02 – Edition 04/2022 – Specifications are subject to modifications
© Copyright 2010-2022 MARPOSS S.p.A. (Italy) – All rights reserved.

MARPOSS,  and Marposs product names/signs mentioned or shown herein are registered trademarks or trademarks of Marposs in the United States and other countries. The rights, if any, of third parties on trademarks or registered trademarks mentioned in this publication are acknowledged to the respective owners.

Marposs has an integrated system for Company quality, environmental and safety management, with ISO 9001, ISO 14001 and OHSAS 18001 certification.



Download the latest version of this document

