

Illustration similar

## TOOL & PROCESS MONITORING GENIOR MODULAR UNIT FOR ACCELEROMETERS

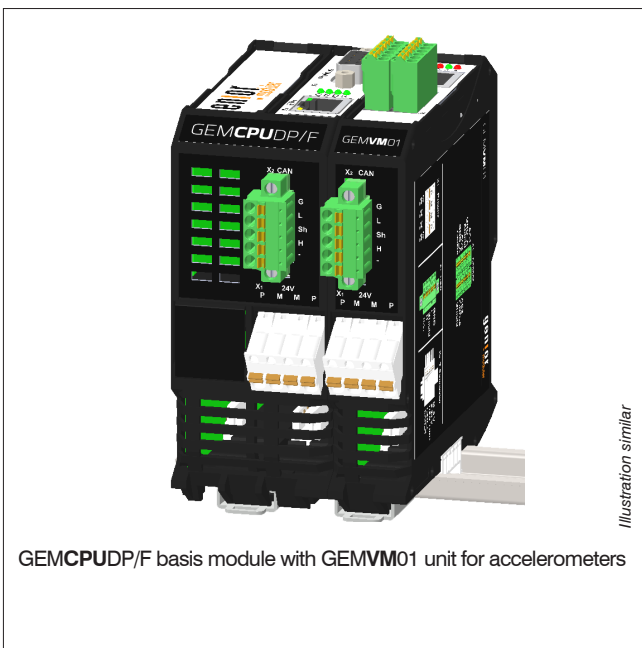

Illustration similar

GEMCPUDP/F basis module with GEMVM01 unit for accelerometers

### Properties

- Component of the tool and process monitoring system GENIOR MODULAR
- 3 independent sensor inputs (IEPE standard)
- 10 Hz ... 5.6 kHz frequency range
- Selectable band-pass filter (minimum 200 Hz)
- 25 kHz sampling rate
- 16 bit resolution

### Available Signals

- 3 x vibration velocity (mm/sec)
- 3 x acceleration (g)

# Tool & Process Monitoring

## GENIOR MODULAR unit for accelerometers

### GEMVM01

	<b>O830Z710102</b>
Dimensions	see drawing
Mounting	Standard mounting rail according to DIN EN 60715
Weight	155 g
Material	Polyamide PA6.6
Flammability class	VO (UL94)
Storage temperature	-20 °C ... +60 °C
Operating temperature	0 °C ... +50 °C
Relative humidity	5 – 85 % without condensation
Degree of protection	IP20
Contacting	Spring terminal, in-rail bus connector
Voltage supply	24 V DC $\pm$ 20 % max. 5 % ripple (via in-rail bus connector)
Nominal current consumption	max. 250 mA
Interface	ARTIS CAN bus
Resolution	16 bit
Measuring inputs	3 x IEPE
Accuracy	< 0.5 %
Frequency range	10 Hz ... 5.6 kHz
Sampling rate	25 kHz
Conformity	CE

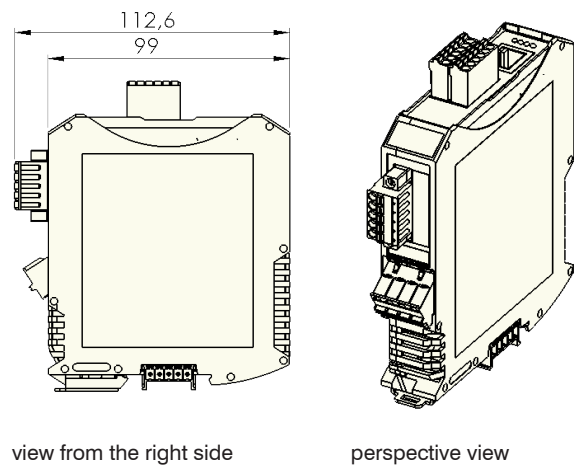
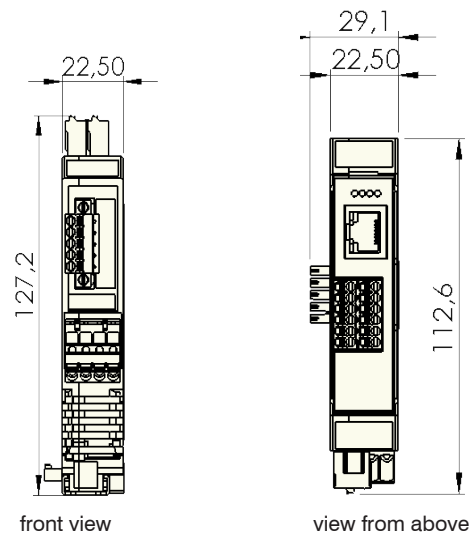

[www.marposs.com](http://www.marposs.com)

For a full list of address locations, please consult the Marposs official website

ODN6422EN02 – Edition 02/2019 – Specifications are subject to modifications  
© Copyright 2019 MARPOSS Monitoring Solutions GmbH (Germany) – All rights reserved.

ARTIS and Marposs product names/signs mentioned or shown herein are registered trademarks or trademarks of Marposs in the United States and other countries. The rights, if any, of third parties on trademarks or registered trademarks mentioned in the present publication are acknowledged to the respective owners.

Marposs has an integrated system to manage the Company quality, the environment and safety, attested by ISO 9001, ISO 14001 and OHSAS 18001 certifications. Marposs has further been qualified EAQF 94 and has obtained the Q1 Award.



Download the latest version of this document