

Illustration similar

## TOOL & PROCESS MONITORING GENIOR MODULAR UNIT FOR FORCE-, STRAIN- AND FLOW SENSORS

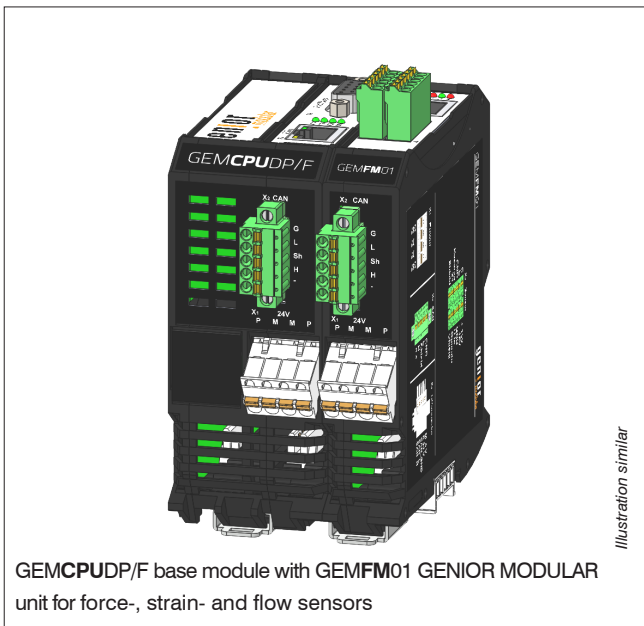

Illustration similar

GEMCPUDP/F base module with GEMFM01 GENIOR MODULAR unit for force-, strain- and flow sensors

### Properties

- Component of the tool and process monitoring system GENIOR MODULAR
- 1 sensor input
- High sampling rate
- Transmission of measuring data via ARTIS CAN bus
- Simple installation in the electrical cabinet of the machine

### Available Signals

- Measuring transducer for ARTIS force-, strain- and flow sensors
- Analog standard signals
  - 0 V...10 V
  - 10 V...+10 V
  - 0 mA...20 mA
  - 4 mA...20 mA

# Tool & Process Monitoring

## GENIOR MODULAR Unit for Force-, Strain and Flow Sensors

### GEMFM01

	O830Z710308
Dimensions	see drawing
Mounting	Mounting rail acc. to DIN EN 60715
Weight	155 g
Material	Polyamide PA6.6
Flammability class	VO (UL94)
Storage temperature	-20 °C...+60 °C
Operating temperature	0 °C...+50 °C
Rel. humidity	5 – 85 % without condensation
Degree of protection	IP20
Contacting	Spring terminals, via in-rail bus connector
Voltage supplyx	24 V DC±20 % max. 5 % ripple (via in-rail bus connector)
Nominal current consumption	max. 250 mA
Output voltage	± 15 V (max. 50 mA)
Interface	ARTIS CAN bus
Resolution	16 bit
Accuracy	0.5 %
Measuring input	±10 V
Frequency range	0...10 kHz
Sampling rate	50 kHz
Switching output Operate	0..15 V
Switching output X	0..15 V
Conformity	CE

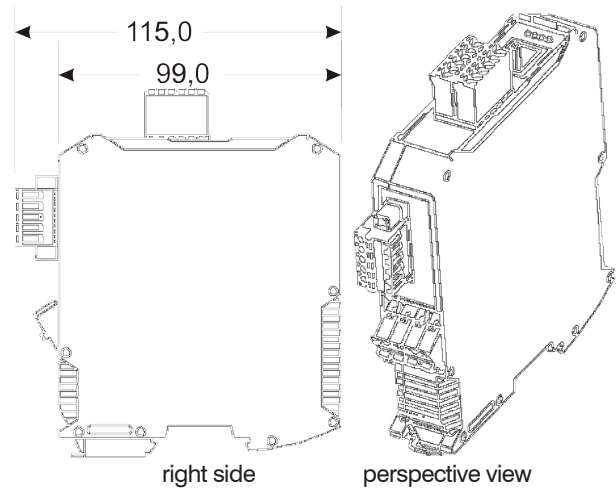
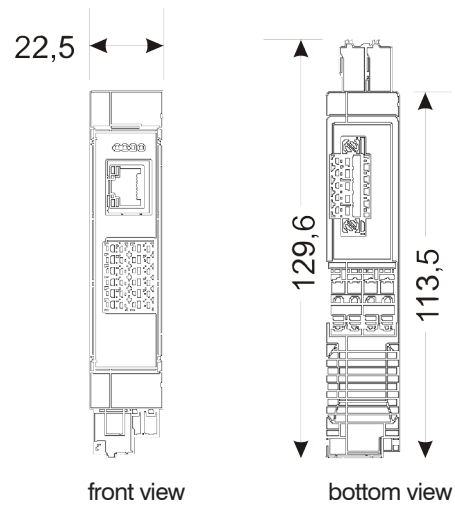

[www.marposs.com](http://www.marposs.com)

For a full list of address locations, please consult the Marposs official website

ODN6422EN03 – Edition 02/2019 – Specifications are subject to modifications  
© Copyright 2019 MARPOSS Monitoring Solutions GmbH (Germany) – All rights reserved.

ARTIS and Marposs product names/signs mentioned or shown herein are registered trademarks or trademarks of Marposs in the United States and other countries. The rights, if any, of third parties on trademarks or registered trademarks mentioned in the present publication are acknowledged to the respective owners.

Marposs has an integrated system to manage the Company quality, the environment and safety, attested by ISO 9001, ISO 14001 and OHSAS 18001 certifications. Marposs has further been qualified EAQF 94 and has obtained the Q1 Award.



Download the latest version of this document