

# MARPOSS

**DIVA**  
DENTAL IMPLANT  
VERIFICATION  
& AUTOMATION





An automatic fully integrated system for quality control of dental implant components. The system performs high precision dimensional measurements and functional tests on screws and implant components, ensuring consistent reliability throughout the production process. An anthropomorphic robot manages the handling of components between stations, guaranteeing continuity, repeatability, and outstanding productivity.

## MAIN CHARACTERISTICS

- Fully automatic system
- High flexibility to process different types of components
- Micrometric precision in non contact internal and external dimensional measurements
- Extremely short inspection time
- Complete traceability
- Intelligent scrap management
- Modular stations that can be enabled or disabled via recipe
- Efficient and intuitive recipe creation and management
- Optional integration with MES/ERP systems

## DATA SHEET

CYCLE RATE	≈15s
EFFICIENCY	95%
PRODUCTION RATE	≈240 components/h
SIZE (hld)	2100 x 2000 x 1500 mm

## COMPONENT CATEGORIES

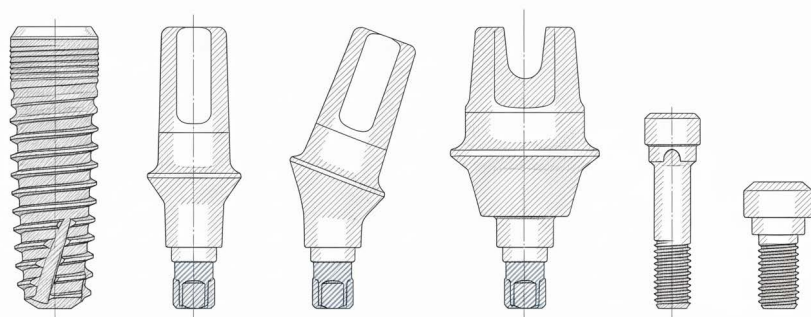

IMPLANT SCREW

CONNECTION SCREW

COVER SCREW

HEALING ABUTMENT

ABUTMENT (STRAIGHT/ANGLED)

MUA (STRAIGHT/ANGLED)

Our highly flexible system, combined with a comprehensive set of measurement stations, enables thorough inspection across a wide variety of components with different geometries and profiles. Each part is inspected through micrometric precision measurements that verify all critical features: diameters, chamfers, lengths, hex shapes, tapers, and threads, both external and internal.

## MACHINE LAYOUT

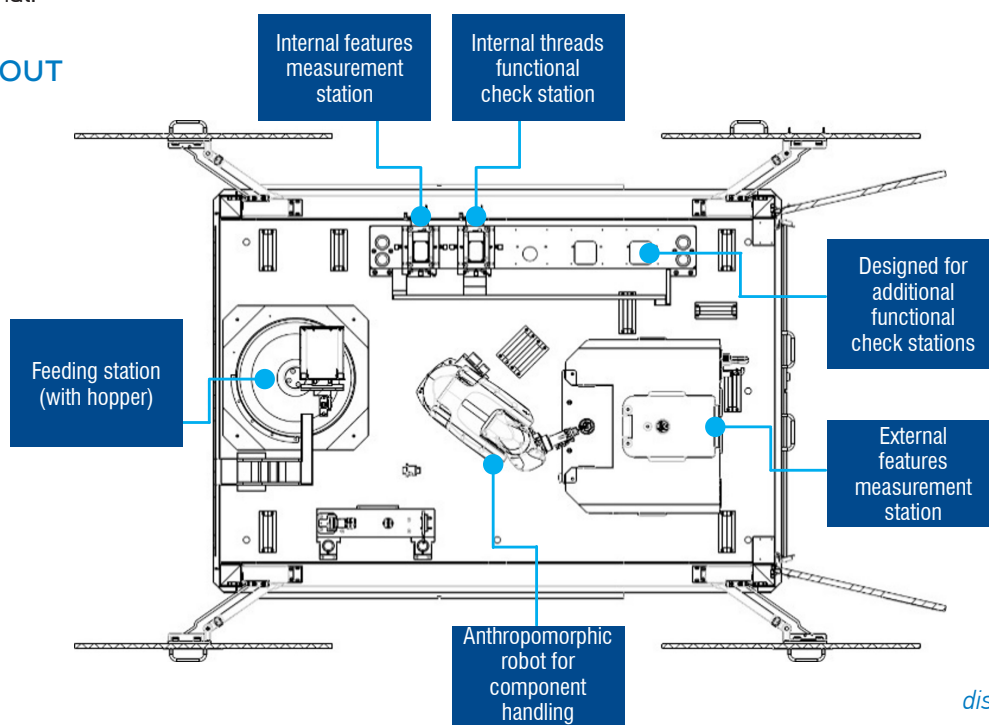

[discover more](#)



**Edition 05/2026 - Specifications are subject to modifications. © Copyright 2026 Marposs S.p.A. - All rights reserved.**

This document and its content are exclusive property of Marposs S.p.A. or other companies of the Marposs Group and they cannot be used to train any artificial intelligence, machine learning, large language models, or other similar networks, algorithms, or systems etc..

Without prior written consent, they cannot be used, totally or partially, for purposes different from those expressly allowed.

Offenders will be prosecuted. The rights of third parties are acknowledged to the respective owners.

MARPOSS, and other names/signs of the Marposs Group shown therein are registered trademarks or trademarks of Marposs S.p.A. or other companies of the Group in the U.S.A. and other Countries.

Some models of the product line, or parts of them, may be subject to export restrictions if exported outside the European Union or may be subject to restrictive measures adopted by the competent national, supranational or international authorities.