

AEROEL XPLORELINE^X



Use the Xactum Intelligent Laser Micrometers as on-line diameter gauges, in the Xplorelinex configuration: with no other instrument can you measure diameters so quickly, so accurately and so easily.

It's the ideal instrument for the on-line diameter monitoring of continuous products like electric cable, plastic tubes, extruded profiles, glass tubes, etc.

Thanks to Aeroel, outstanding laser technology, high accuracy, easy use and excellent reliability are offered at affordable conditions: payback can be realized in just a few months

MARPOSS

The Xploreline.X

The XLS gauges are programmed with a dedicated software and are completed with a display unit and a remote control: using such a measuring "system" you can monitor the diameter on-line, measuring fast moving products very accurately, to achieve 100% check and to avoid any dimensional non-conformity.



Measuring modes

The gauge is continuously reading the **Diameter D** and the **Centre Position C** of the product, the scan frequency of the gauge is 1500 Hz. Each single scan reading is called **Single Scan Value**: the related measuring repeatability is specified in the gauge performance table and it is so good that any Single Scan Value can be considered to detect any flaw that turns into a diameter change. It is therefore possible to **look for small diameter changes**, having a minimum length which is depending upon the the scanning pitch. ⁽¹⁾

To improve the measuring repeatability or to filter small product irregularities, **it is possible to average some N consecutive Single Scan Values**

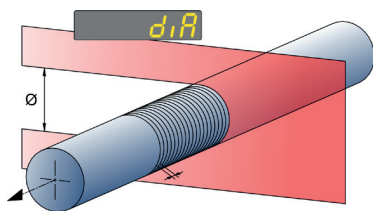

and to get their average value, Instant Value; N is programmable by the user and can be as low as N=1, to make the **Instant Values** coincide with the Single Scan Values. The measuring repeatability of an Instant Value can be computed by dividing the single scan repeatability by the square root of the number of averaged scans N.

In addition **it is also possible to consider a group of K** ⁽²⁾ **consecutive Instant Values** and among them to take the Maximum and **Minimum Values** and to compute their **Average Value** ⁽³⁾ and the **Range**=Maximum-Minimum. ⁽⁴⁾

For instance, the following values are computed and displayed: Davg, Dmax, Dmin, Range=Dmax-Dmin and the Average Center Position. By properly setting N and K it is possible to program the system to perform flaw detection or an average diameter measurement or to measure other product dimensions that correspond to maximum and minimum values.

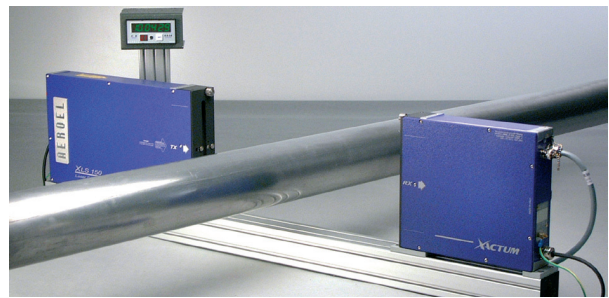

Exclusive Aeroel features



- The scanning motor based on the **Fluid Dynamic Bearing technology**, without ball bearing works perfectly, with no wear.
- **The NO-VAR option** allows you to automatically compensate for the expansion of the part when room temperature changes. The user only needs to program the proper coefficient of thermal expansion of the part.
- **The Web Server** allows you to connect the sensor through the Ethernet line to any Internet browser and "see it" as a website, where you can view the measures, set-up and program the gauge and even display the video signal (light pulse).

Types of measurements

It measures the diameter **D** and the position **C** of the **Center of the part**, from the Center of the measuring field. The part can be **opaque or transparent**.

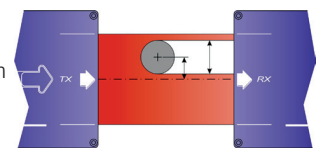

System composition

The Xploreline.X system is composed by:

- a single axis Xactum gauge, XLS40, XLS80 or XLS150 type
- Xploreline.X software pre loaded in the gauge
- DM-200 multi-colour LED display
- universal power supply
- an I.R. Remote Control
- connecting cable L=5m, between gauge and display

Some optional accessories which are available:

- telescopic stand for the laser gauge
- compressed air windows for the gauge
- extension cables
- Hand-held programming terminal
- GageXcom software for PC communication
- PC Software for networking



Measurement examples

Measuring the average diameter and looking for flaws:
set N=1 and K large enough to smooth the diameter readings.

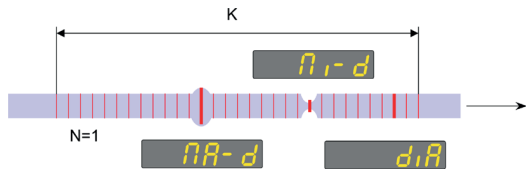

Strip width measurement:
a slight product twisting can improve the accuracy.

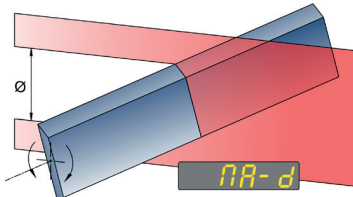

Checking corrugated product:
the peak values and the waviness can be detected.

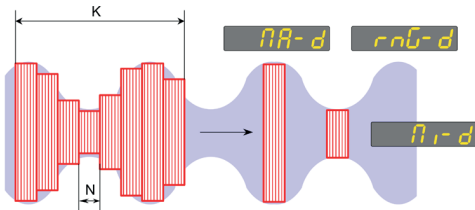

Display and remote control



Multicolour LED display to show the measured values and to allow system programming through the IR remote control. The measured and programmed data can be scrolled on the

display by using the remote control or the SET key on the display panel.

It is possible to save in memory, in a **Product Library**, up to 1000 different sets of programmed parameters, each one for the specific part to be checked.

The display color will change into the color corresponding to the tolerance status of the shown variable (**green, orange or red**).

The display unit includes **4 programmable alarm output lines** to drive additional external devices.

Optional analog output, $\pm 10V$ proportional to the diameter deviation from the nominal set point ⁽⁵⁾

Simple and quick **programming using the remote control** keys and the messages on the display.

Offset function for user re-mastering.

Input lines for meter counting/resetting pulses, to compute and display the product length

Selectable Measuring Unit inch/mm and Resolution (to $0.01 \mu m / 1 \times 10^{-6}$ inch). ⁽⁶⁾

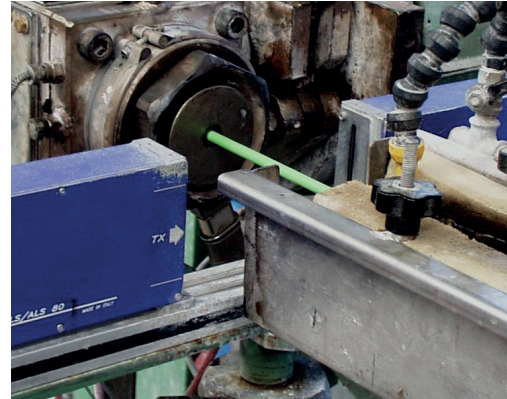

PC interface

An **external/remote computer** can be connected to the system through the **Ethernet/RS232** interface, to **program the system or to get the measured data**. The Ethernet line is very useful to network several systems.

The **Web Server** allows you to connect the sensor through the Ethernet line to any Internet browser and "see it" as a website

It is possible to use the RS232 port in VT100 emulation mode, which makes it possible the connection of the system to a PC using the **Windows** ⁽⁷⁾ **Hyperterminal** program or to a hand-held programming terminal.

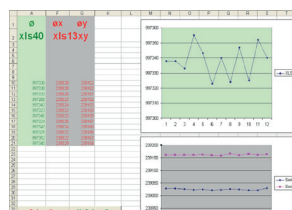

Using the optional **GageXcom software** provided by Aeroel, you can use **Excel** ⁽⁷⁾ spreadsheets to set-up the system and to get all measured results: you can write your own applications by writing

suitable Excel Macros and using standard Excel functions to process data.

(1) The scanning pitch is given by the line speed divided by the gauge scanning frequency

(3) K is programmable by the user: its minimum value is 12.

(3) The Average Value is the result of an average over N x K Instant values.

(4) The Max, Min, Avg and Range Values, computed over a group of K Instant Values, are called Extreme Values.

(5) When the analog output is used, 2 output lines only are available.

(6) Due to the display limitations, the 6 most significant digits only are shown; the full resolution is anyway available using the serial output ports.

(7) Windows and Excel are registered trademarks of Microsoft Corporation

Technical characteristics

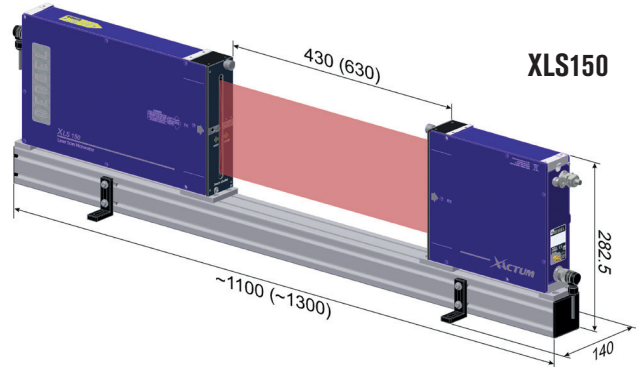
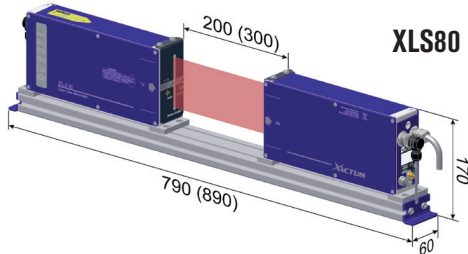
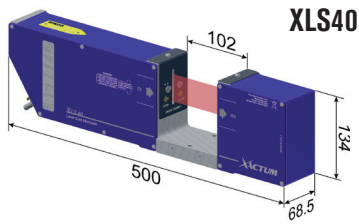

Tutte le dimensioni sono in mm.

DISPLAY AND ALARMS MODULE DM-200



Main Display LED 6 digits, 7 segments multicolour
Sub Display LED 2 digit
6 Warning lights for the Status of the Inputs and the Outputs
4 Outputs protected PNP, I_{max}: 100 mA
2 Inputs PNP, I_{typ}: 15 mA
 Optional **analog output**: ± 10 V
Dimensions: 97 x 49 x 105 mm
Weight: 0.3 kg
Power supply: 24 VDC 150 mA



I.R. REMOTE CONTROL

Size: 180 x 50 x 26 mm
Weight: 80 g (without batteries)
Power supply: 2 AAA 1.5 V batteries

Available models

	XPLORELINEX40	XPLORELINEX80	XPLORELINEX150
Gauge Model	XLS40	XLS80	XLS150
Beam height (mm)	40	80	150
Measurement range (mm)	From 0.06 to 38	From 0.75 to 78	From 0.8 to 149
Scanning rate (Hz)	1500		
Resolution (µm)	fino a 0.01		
Repeatability (µm)	± 0.07 at best	± 0.2 at best	± 0.4 at best
Linearity (µm)	± 0.5 at best	± 1 at best	± 3 at best

Specifications subject to change without notice. For additional details and complete specifications please see the gauge data sheet.



MARPOSS
AEROEL

