

AEROEL

MECLAB^T40

Bench-top Laser Micrometer



MECLAB.T40 is a high precision laser instrument for quick and simple diameter measurements of hard metal blanks and full carbide cutting tools, odd or even edges. It's ideal for the off-line checking of

- drill bits
- end mills
- reamers
- cutting tools

In addition it can be also used to check the diameter and the ovality of

- hard metal blanks
- ground pins or cylinders

Using no PC, it can be really used in the workshop, close to the machine

... simple ... quick ... accurate ... cost-effective

MARPOSS



System operation

The part being checked is inserted on a double V fixture, on a manually driven slide with micrometric adjustment equipped with a magnetic digital scale to display the displacement of the part itself; the position is continuously displayed on the screen.

Using an exclusive guided procedure, the operator seeks the starting point, moves the part to the measurement position and starts the measuring cycle: the part is manually or automatically rotated, taking care to keep it pushed against the V blocks to assure a "zero run-out" rotation, that is a rotation around a perfectly fixed axis.

During the rotation period, which is set by the operator or automatically set by the software, the laser sensor scans the part at 1500 samples/second and stores all the measurements related to the positions of the upper and lower edge of the part.

An exclusive data processing software performs an accurate and repeatable measurement of the cutting diameter and run-out the part, for both odd or even fluted parts. The measured results are updated and displayed in real time, giving the operator the information when to stop the check.

When measuring round parts, i.e. hard metal blanks, checks the diameter, the ovality and the end run-out of the part.

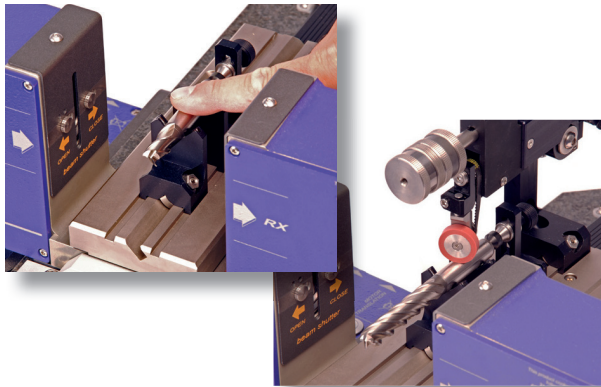
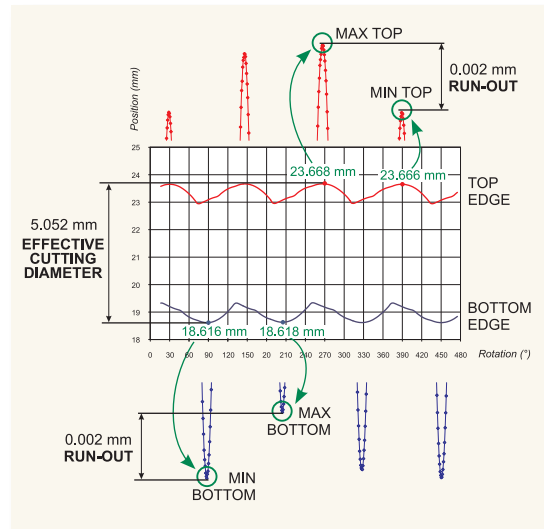

The Xactum Technology

The Xactum XLS40/1500/B Laser Micrometer is an extremely accurate and repeatable measuring instrument, featuring:

- Wide measuring field: 40 mm
- Excellent linearity: $\pm 0.5 \mu\text{m}$
- Outstanding repeatability: $\pm 0.05 \mu\text{m}$
- Permanent self-calibration
- NO-VAR technology: no measuring drift due to changing room temperature by programming the coefficient of thermal expansion of the part



System Composition

The basic system, Manual version, consists of:

- XLS40/1500/B Xactum Intelligent Laser Sensor.
- CE-200 Operator's Interface Panel.
- Linear stage, manually driven, with micrometric adjustment and magnetic digital scale, mounted on a flat granite base.
- Fixture for the part, with a couple of V blocks and a stopper.
- Meclab.T software pre-installed in the sensor.
- Power supply and connecting cables.

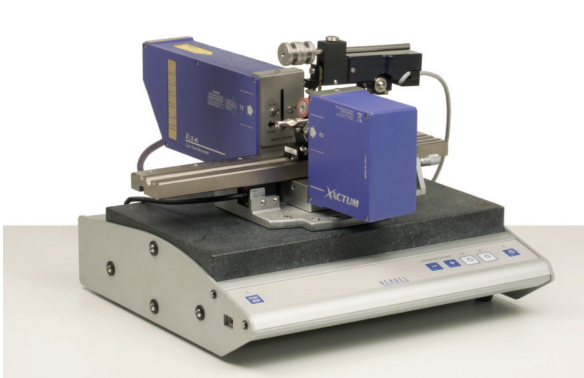

The Automatic version includes in addition:

- Motor driven device to rotate the part, with friction driving wheel and stepper motor.
- Equipped base, mounted under the granite base containing the electronic driver for the motor.

Common Options:

- NO-VAR software option for the automatic self-compensation of the part thermal expansion, by programming its thermal expansion coefficient.
- GageXcom Software for data transfer to Excel.

Very flexible in use

Tool measurement

Using the tool dedicated menu, it is possible to check full carbide tools with ODD or EVEN cutting edges. The part must be rotated (manually or automatically) to detect the max and min positions of the Bottom and Top edges.

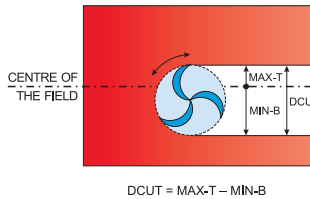

Effective cutting diameter: is the diameter of the ideal hole obtainable with the tip mounted on an ideal spindle with zero runout.

Diameter of the tool section: is the diameter of the ideal circle passing through the tips of the cutting edges. It is calculated by applying a special algorithm and assuming the hypothesis that all the edges have the same radius from the center of the section and they are equally spaced in angle.

Runout: is measured like the maximum change of the upper (or lower) edge peak position (max peak – min peak) during a complete rotation



Measuring hard metal blanks

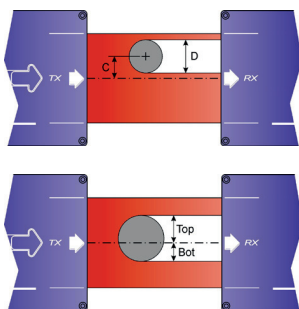

The Meclab.T System measures the part diameter D and the position of the part axis C or the positions of the edges of the part, Tot (upper) and Bot (lower), all referred to the center of the measuring field.

3 measuring modes are available: **Free running**, **On-Command Single**

Shot and On-Command Continuous. An additional **Auto-start** mode is included to trigger automatically a Single Shot measurement when a part is detected by the laser. During the **On-Command Continuous** mode, for every measured variable the maximum, minimum and average values are retained, as well as the Range value = Max – Min, but the user can enable and display only the desired values. In this way, by selecting the appropriate type and mode of measurement and moving the part into the laser beam, it is also possible to check the ovality and the straightness of hard metal blanks, as run-out of the center position (Range of C) during a complete rotation.

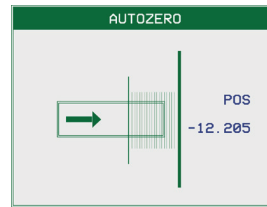

Multiple language pop-up menus for easy set-up and programming.

Display millimeters or inches

Automatic seeking of the “zero point”



Reading the slide position

Quick change over of the cutting edge number

Display of 3 measured variables

Quick tolerance check and alarm outputs

1000 parts library for quick programming

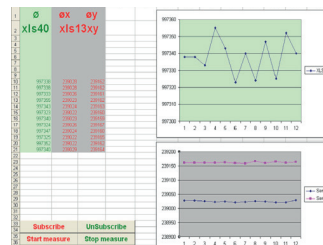
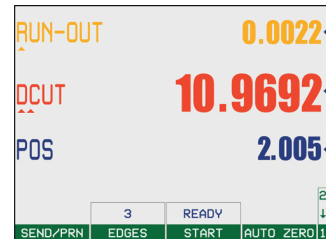

I/O Lines for Easy Interfacing and start/stop input for a foot switch

Connection to a PC and easy Excel interface

Benefits

No error due to the hysteresis (inversion error) which is typical of all dial indicator gauges (see QR-code video).

Unique to check odd fluted parts!

Using no PC, it's ideal to be placed in the workshop, close to the machine.

Manual or automatic part rotation.

Contactless measurement: no part damage or scratches.

Objective and highly reproducible results: no matter about the operator's skill.

Extremely easy and quick to use: reduces inspection time and improves measurement capability.

Highly flexible: different components and sizes can be measured without gauge re-mastering.

Ultra accurate: it measures to an accuracy that before you had only in a metrology room, using time consuming, expensive equipment and specialized personnel.



Specifications

Manual Version

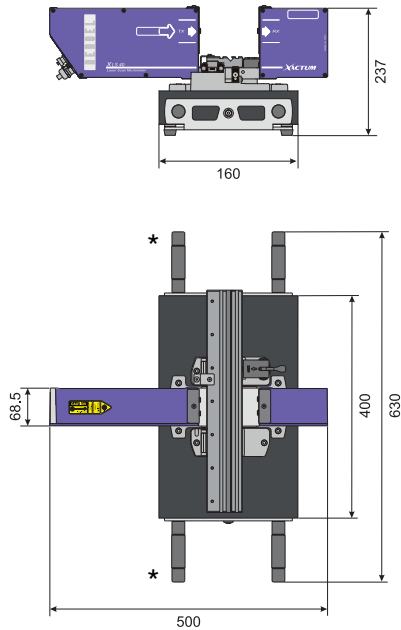

Automatic Version

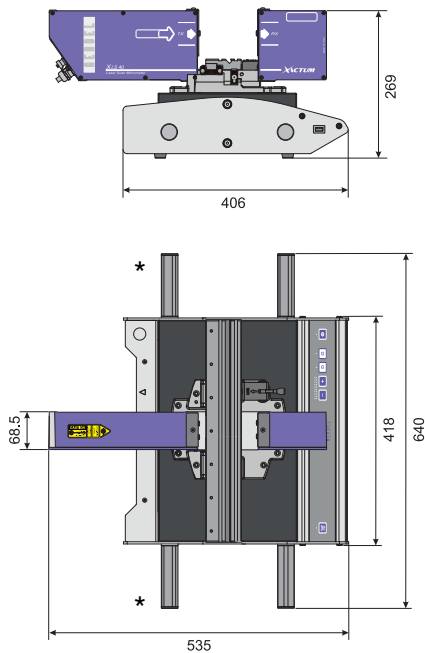

(*) Removable handles

All dimensions are in mm.

Specifications subject to change without notice. For additional details and complete specifications please see the gauge data sheet.

Xactum XLS40/1500/B Laser Micrometer		
Measurable Diameters	(mm)	0.06 - 38
Linearity (Centred Product)	(μm)	± 0.5
Linearity (in the Measuring Plane)	(μm)	± 0.5
Repeatability ($T=1\text{s}, \pm 2\sigma$)	(μm)	± 0.07
Beam Spot Size (s,l)	(mm)	0.06 x 0.1
Scanning Frequency	(Hz)	1500
Gauge Thermal Coefficient	($\mu\text{m}/\text{m}^\circ\text{C}$)	- 11.5
Laser Source	Visible Laser Diode; $\lambda = 650\text{ nm}$	
Meclab.T40 System - Manual Version		
Dimensions	(mm)	500 x 630 x 237
Weight	(kg)	30
Meclab.T40 System - Automatic Version		
Dimensions	(mm)	535 x 640 x 269
Weight	(kg)	32

Fixture

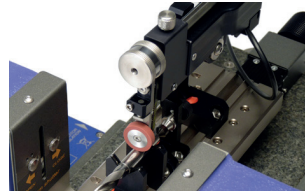

Precision linear slide on a flat granite base: stainless steel table with V groove, overall length 400 mm, range 160 mm, manual and micrometric drive

Position transducer: magnetic digital read out, resolution 0.005 mm

Part holding: with a couple of 90° V blocks and a stopper, adjustable along the slide. Bearing on hard metal bars (interchangeable if worn out) with special cover, for low friction coefficient (0.1) and high hardness (2000–4000 HV).

Fixture capacity: shank diameter from 1 to 20 mm, shank length from 22 to 100 mm, max part length 200 mm (for different dimensions, please contact Aeroel).

Optional Rotation device: motor driven, with friction wheel and stepper motor driver, local or automatic control.

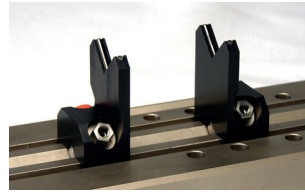

GE-200 Operator's Interface Panel



Color **LCD Display**, 640x480, backlit

"Touch-Sensitive" **capacitive keyboard**, with 35 keys and 7 warning LED

RS485 interface to connect the XLS gauges

8 protected PNP outputs, 5 PNP inputs, 2 inputs to the gauge

Ethernet & RS232 ports and Centronics output for parallel printer

2 configurable analog outputs

Dimensions: 132 x 350 x 76.5 mm (panel alone)

Weight: 2 kg (panel), 3.1 kg (table-top version)

Power supply: 24 VDC, 100 mA Typical (1 A max)



MARPOSS
AEROEL

esq
ISO 9001:2015

CERTIFIED
Net
MANAGEMENT SYSTEM