

# NON CONTACT VISUAL TOOL SETTER

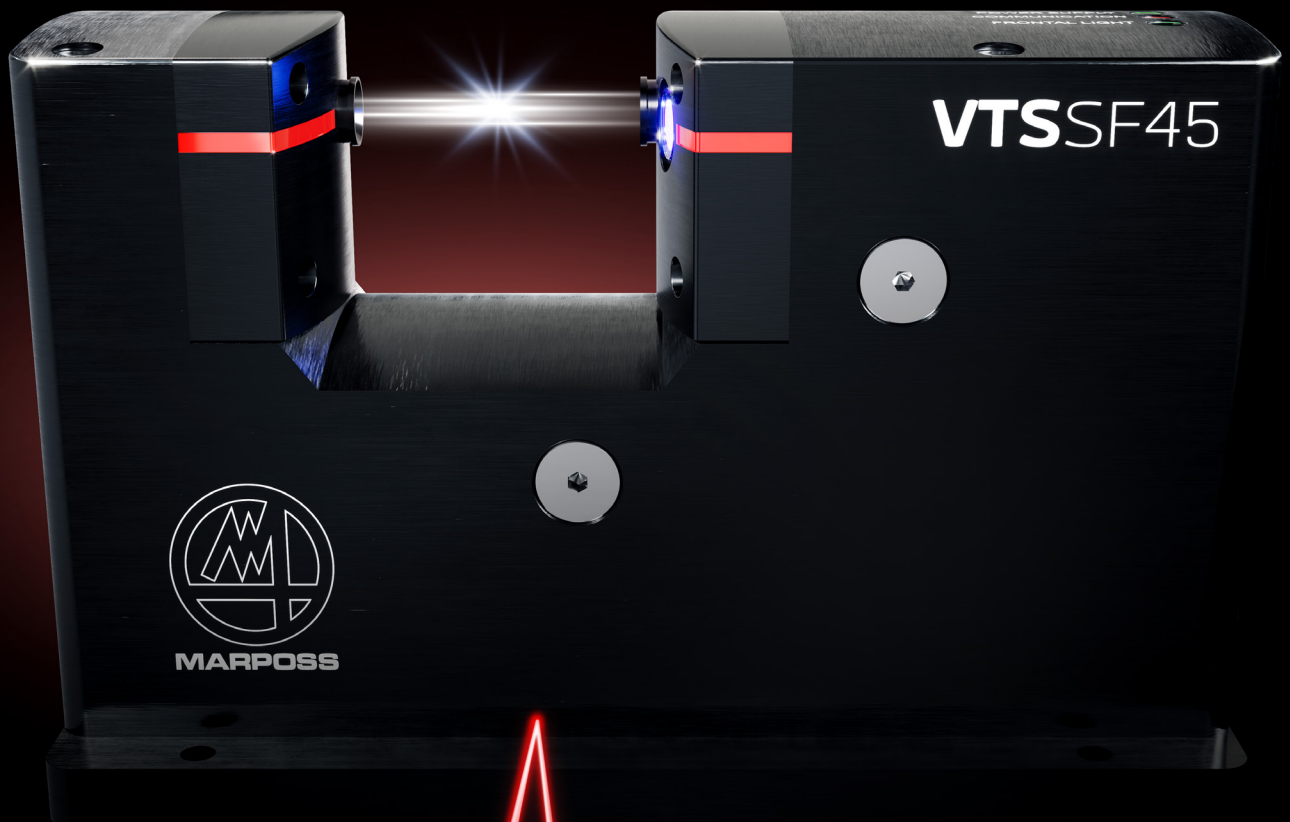

PERFECTION

IS BORN

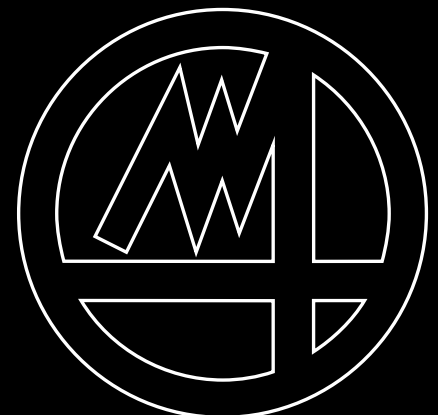

**MARPOSS**

## VTS SF-45 Compact

Machines dedicated to mold making or micro-milling machining tend to be small, so that every in-process measuring device runs into a constraint: limited space.

That is why Marposs introduces its new visual tool setter: the VTS SF-45 Compact.

The new mechanical design maintains the same repeatability and accuracy performances that remain the best on the market.

The new size, on the other hand, makes it ideal when space in the machine is an issue.

New compact VTS: same measurement performances with reduced size.

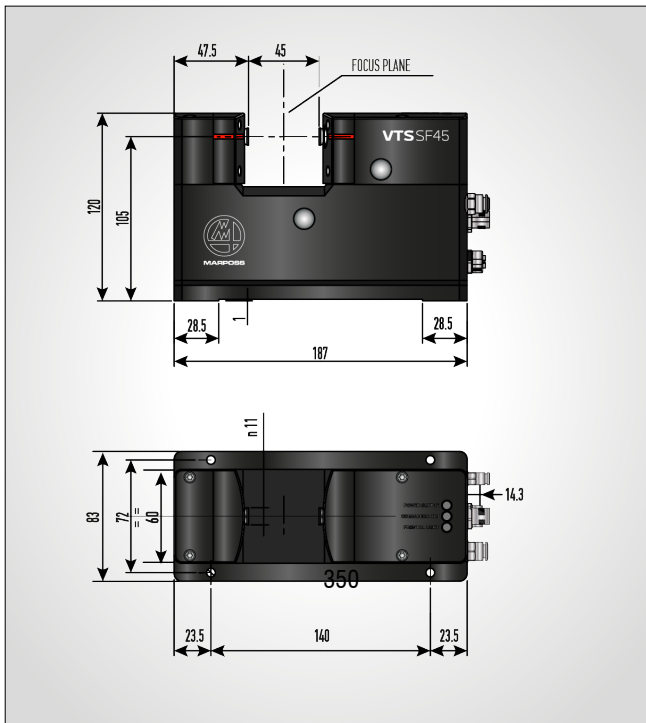

Type of actuation	Pneumatic	
DESCRIPTION OF THE DEVICE	Non-contact tool checks for CNC machines	
MEASURABLE DIAMETERS	min	10 $\mu\text{m}$
	max	0.6 mm double side / 40 mm single side
Resolution	0.1 $\mu\text{m}$	
Repeatability $6\sigma^*$	0.2 $\mu\text{m}$	
Weight	VTS-SU: ~2,7 kg	
WORKING TEMPERATURE	5 - 50° C	
RELATIVE HUMIDITY	90% max	
PROTECTION RATING (IEC 60529)	IP67	

(\* ) = The double side L and  $\varnothing$  values are guaranteed.  
The single side L and  $\varnothing$  values depend on the machine.

For a full list of address locations, please consult the Marposs official website  
Edition 10/2022 - Specifications are subject to modifications © Copyright 2022 MARPOSS S.p.A. (Italy) - All rights reserved.

MARPOSS, logo and Marposs product names/signs mentioned or shown herein are registered trademarks or trademarks of Marposs in the United States and other countries. The rights, if any, of third parties on trademarks or registered trademarks mentioned in the present publication are acknowledged to the respective owners.

Marposs has an integrated system to manage the Company quality, the environment and safety, attested by ISO 9001, ISO 14001 and OHSAS 18001 certifications. Marposs has further been qualified EAQF 94 and has obtained the Q1-Award.