



SOLUTIONS FOR **ELECTRIC DRIVE UNIT** PRODUCTION



MARPOSS





EPOWERTRAIN solutions

MARPOSS: YOUR TRADITIONAL PARTNER FOR THE NEW ELECTRO-MOBILITY CHALLENGE

For nearly 70 years, our mission has been to work side-by-side with customers to guarantee quality control in the entire production process. The wide range of technologies and products available, together with a worldwide presence, have made Marposs the ideal partner for OEMs, first and second tiers, as well as machine tool makers operating in the automotive industry.

In times of great change, Marposs is taking up the challenge to remain a strong partner for the automotive market in the e-mobility era. The traditional product lines are integrated with new technologies to provide a mix of gauging, inspection and testing solutions that ensure complete monitoring of the main EV component production processes. Marposs offers a full range of solutions for the control and optimization of the various manufacturing steps, and the control of individual components up to final assembly operations and functional check of any assembled system.





HOUSING

- DIE CASTING PROCESS MONITORING
- TOOL CHECKING AND PROCESS MONITORING IN METAL CUTTING
- DIMENSIONAL GAUGING AND VISUAL INSPECTION
- LEAK TESTING PRODUCTS AND APPLICATIONS



STATOR

- SPECIAL SOLUTION FOR GAUGING AND INSPECTION
- ELECTRICAL TESTING OF STATORS



HAIRPINS

- LASER SYSTEM FOR IN-LINE CONTROL OF ENAMELLED MAGNET WIRE
- IN LINE GAUGING AND INSPECTION
- OPTICAL GAUGE FOR DIMENSIONAL CHECK



SHEET STACK

- INTELLIGENT PROCESS MONITORING FOR SHEET METAL FORMING
- QUALITY CHECK AND INSPECTION OF LAMINATION SHEET
- CONTACT/NON-CONTACT GAUGING OF STACK ASSEMBLY

QUALITY ASSURANCE OF COMPONENTS FOR ELECTRIC MOTORS

The challenge with the latest generation of electric motors is optimizing the efficiency, quality and cost involved in producing and assembling their components.

The unprecedented global growth of electric motor technology, especially within the automotive sector, brings a whole new set of component reliability expectations to manufacturers and end users. This new trend has implications on the quality control and the process control requests of the production chain.

For this reason, the automotive sector is paying ever-rising attention to the reliability of electric motors, resulting in a shift to produce higher quality components and assemblies.

Marposs produces a complete line of products dedicated to process control, as well as in-line and off-line quality check of every type of motor for **electric vehicles and their components.**

ROTOR & SHAFT

- IN-PROCESS GAUGING FOR THE GRINDING PROCESS
- CUSTOMIZED CONTACT GAUGING SOLUTIONS
- FLEXIBLE OPTICAL SOLUTIONS
- FUNCTIONAL TESTING



INTELLIGENT PROCESS MONITORING FOR SHEET METAL FORMING

Many factors can influence sheet metal stamping operations, making real-time monitoring of processes essential to effective cold forming operations.

By identifying part or tool variations and unexpected events, the process can be optimized to help improve part quality, machine efficiency and limit unplanned costs.

The X-series is a high quality in-process monitoring system for nearly all metal forming processes including stamping. The system allows monitoring of a variety of machines and sensors with different types of monitoring modes. The process signals can be monitored and displayed as peak values, envelope curves, trend or process quality progressions. Sensors (e.g. force, acoustic emission, distance, temperature) placed at machine or tool relevant locations convert process information into electrical signals, which are amplified, filtered and then evaluated with adapted monitoring methods.

QUALITY CHECK AND INSPECTION OF LAMINATION SHEET

Marposs offers a solution for 2D measurement of the lamination sheets through camera and confocal technologies.

CONTACT / NON-CONTACT GAUGING

After stacking (by punch packaging, welding or gluing techniques), it is essential to gauge the height and diameter of the sheet stack. Additionally, the geometry and positions of the slots for the following hairpin process (for stator stacks) or magnets insertion and rotor shaft assembly (for rotor stacks) need to be measured.

Marposs can provide a series of contact and non-contact solutions to carry out more accurate measurements to increase quality assurance.

Special dynamic stations for gauging the rotor sheet-metal stack allow measurement of the inner/outer diameter in different sections as well as checking the cylindricity of the bore by dynamic measurement.

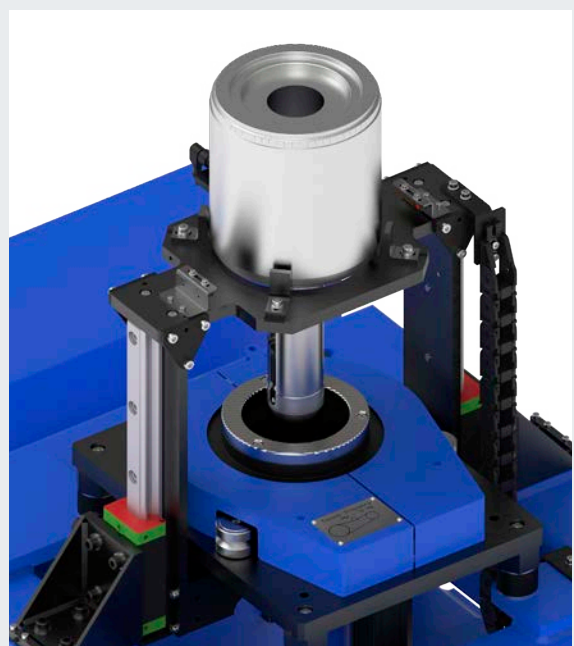



STACK OF SHEETS

The lamination stack, as an important active part in the electric motor, influences its electrical, magnetical and mechanical properties.

The geometry of each single sheet has an effect on the dimensions of the stack of sheets; for this reason machine monitoring solutions, measurements and inspections ensure the highest quality of the final stators and rotors.



“ STAMPING PROCESS
MONITORING:
THE KEY FOR HIGH
QUALITY AND MACHINE
EFFICIENCY IN THE
STACK OF SHEETS
MANUFACTURING ”



IN-PROCESS GAUGING

Rotor shafts are subjected to constant mechanical stresses, due to high rotation speed and torque.

In order to reach the highest quality for these components, it's mandatory to perform extremely accurate grinding operations on certain aspects of them (e.g. bearing seat). Quality of the finished parts and optimized cycles are essential aspects of the whole process.

Marpos's experience in grinding process monitoring is evidenced by a complete portfolio of sensors designed specifically to keep all key parameters under control during the different grinding phases: in-process and post-process gauging, wheel balancing, acoustic emissions, vibration and power.

CUSTOMIZED CONTACT GAUGING SOLUTIONS

Special dynamic stations are proposed for automatic post-process gauging of the shaft or of the rotor assembly.

The run-out of the stack and the spline gear with respect to the bearing axis can be measured together with the outer diameters in multiple sections.

Checking the balancing holes in terms of diameter and depth with laser scanning technology can be an additional feature.

FLEXIBLE OPTICAL SOLUTIONS

With Optoquick and Optoflash product lines, Marpos offers high precision measuring solutions based on 2D optical technology, for fast and extensive quality control on rotor and rotor shafts both in the metrology lab and in the production environment. The combination of tactile sensing and optical technologies (able to work also under the influence of the rotor's magnetic field) enable extended gauging capability at the highest level.

FUNCTIONAL TESTING

Customized manual or automatic systems can be supplied for different testing operations, depending on the type of rotor:

- Check of the magnetic field homogeneity by Back-EMF analysis for permanent magnets rotors
- Check of local defects in bars of squirrel cage rotors for induction motors
- Insulation tests, including Partial Discharge measurement, for wound rotors

OPTICAL MEASURING
– TOP ACCURACY
AND FLEXIBILITY FOR
GAUGING OF ROTOR-
SHAFTS AND ROTORS

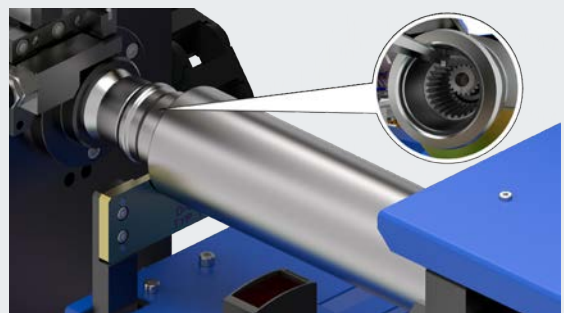



ROTOR & SHAFT

As the central elements of the electric motor, the shaft and the rotor are capable of high speeds and huge torques that the motor transmits to the downstream components. For this reason, it is important that all components fit together precisely with very tight tolerances. This makes it essential to inspect each one to ensure the highest level of quality.

Different rotor versions are used, depending on the type of electric motor:

- Permanent magnet rotor for brushless synchronous motors
- Wound rotors for externally excited synchronous motors
- Squirrel cage rotors for asynchronous motors

Dedicated products and applications are proposed for process control along the complete manufacturing chain, as well as solutions and machines for the quality check, functional testing and complete rotor assembly.

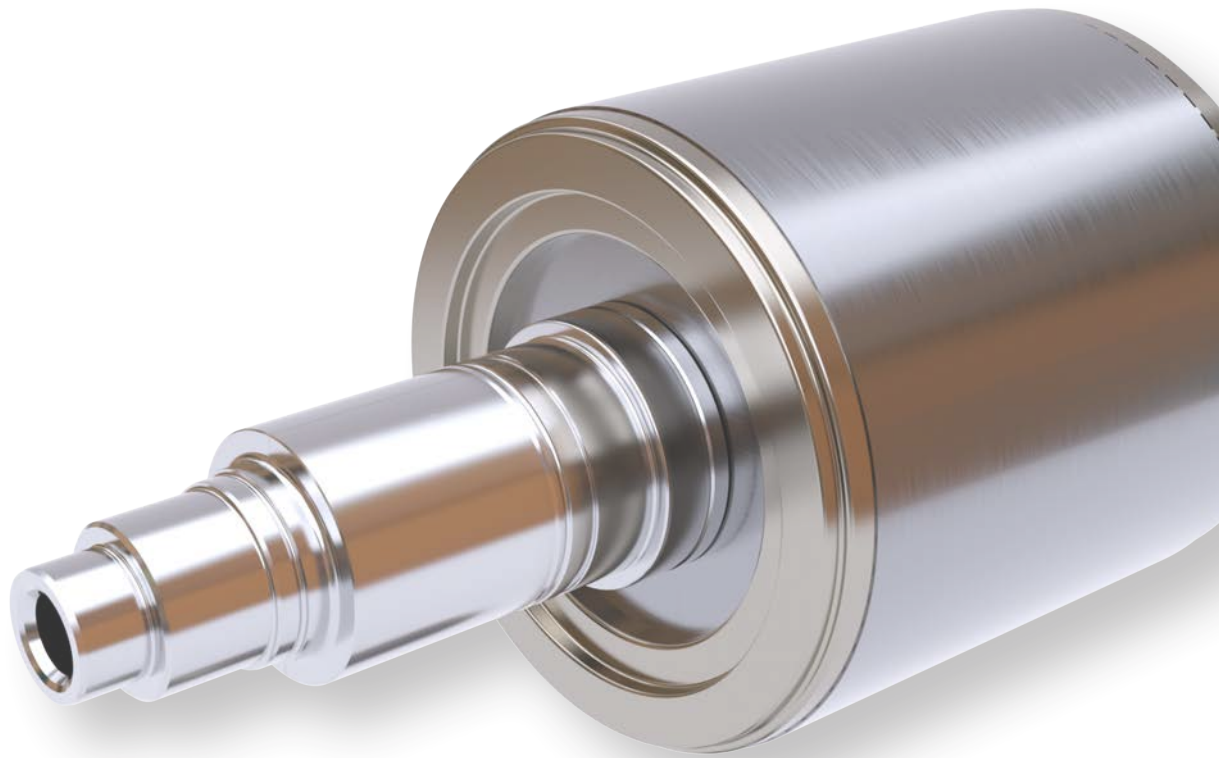

“ “
BACK
ELECTROMOTIVE
FORCE TEST (BEMF) –
THE MOST RELIABLE
SOLUTION FOR END-OF-LINE
FUNCTIONAL TESTING OF
PERMANENT
MAGNET ROTORS “ “



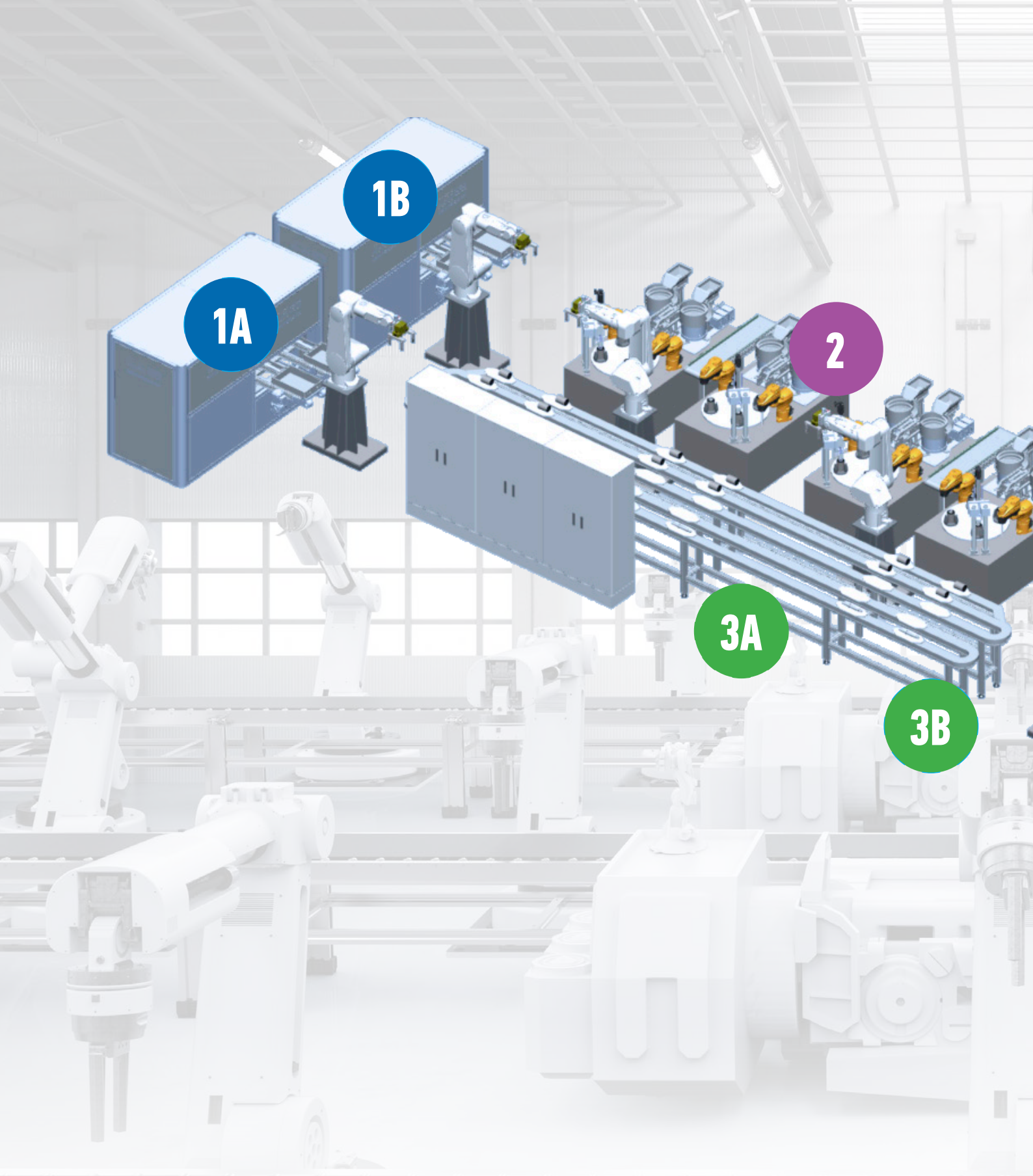

- **1A** BASKET FEEDER: automatic system to feed the stacks stored in baskets
- **1B** BASKET FEEDER: automatic system to feed the shafts stored in baskets
- **2** ROBOTIZED ASSEMBLY: bulk magnets (not magnetized) feeding and stacking into the stacks (four stations in parallel due to cycle time)
- **3A** Pallet conveyors to move the shafts to the presses
- **3B** Pallet conveyors to move the assembled stacks to the presses
- **4** Shaft/stacks/frames assembled into the rotor (two stations in parallel due to cycle time)



ROTOR ASSEMBLY LINE

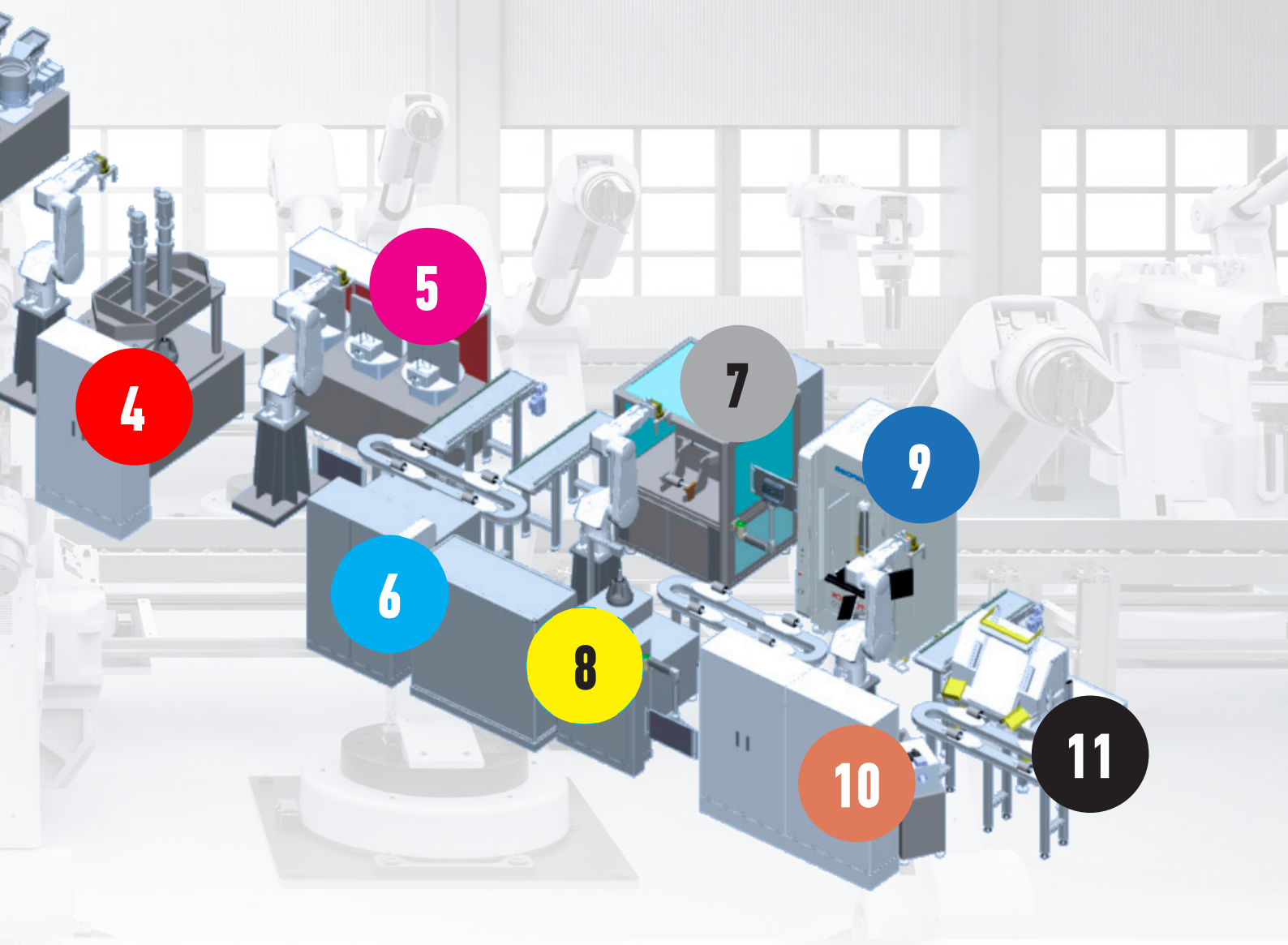

- 5** Rear & drive plates feeding
- 6** OVERSPEED: homogeneous peripheral distribution of the magnets
- 7** BALANCING: rotor balancing on its longitudinal axis

- 8** MAGNETIZATION: ferrite (magnets) magnetizing
- 9** OPTOQUICK: optical dimensional profile measurement
- 10** Laser marking
- 11** BACK EMF: electrical final test



LASER SYSTEM FOR IN-LINE CONTROL OF ENAMELLED MAGNET WIRE

Marposs offers a wide range of ultra-accurate high speed contactless measurement laser gauges for in-line control of enamelled magnet wire having a rectangular or round cross section.

Quadraline is a laser system designed to control the two dimensions (height and width) of extruded or rolled products featuring rectangle-like cross sections, such as magnet wire used in hairpin production. The system can be equipped with a special oscillating fixture ($\pm 5^\circ$ max) to guarantee that the two minimum values corresponding to the section dimension are always detected, whatever the orientation of the wire.

In case of round section wire for wound stators, Marposs recommends the Xploreline XY. This system measures diameter and ovality of the wire and includes the Blistbuster feature that identifies defective portions of the wire (blisters).

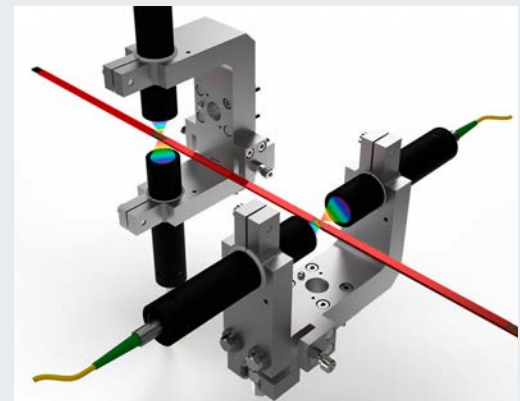
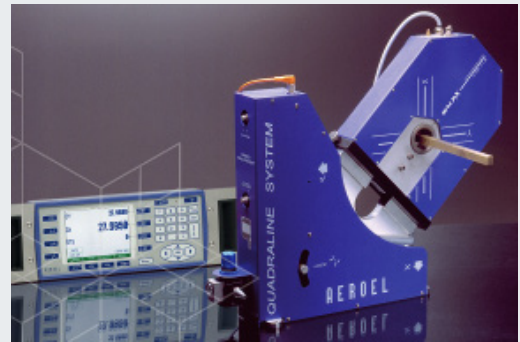

IN-LINE GAUGING AND INSPECTION

The wire that constitutes the hairpin is coated with a precisely formed thin layer of polymer for insulation. In order to guarantee the perfect welding of the hairpins to form the stator windings, it is necessary to completely remove the enamel from the terminals.

Marposs confocal technology can guarantee continuous in-line measurement of the enamel thickness on the 4 faces of the wire. The measured data can also be used to guide the subsequent stripping process, mechanical or laser, in order to optimize the enamel removal.

Interferometric technology can be proposed in some cases for the gauging of the stripped area, looking for residuals of enamel that have not been removed.

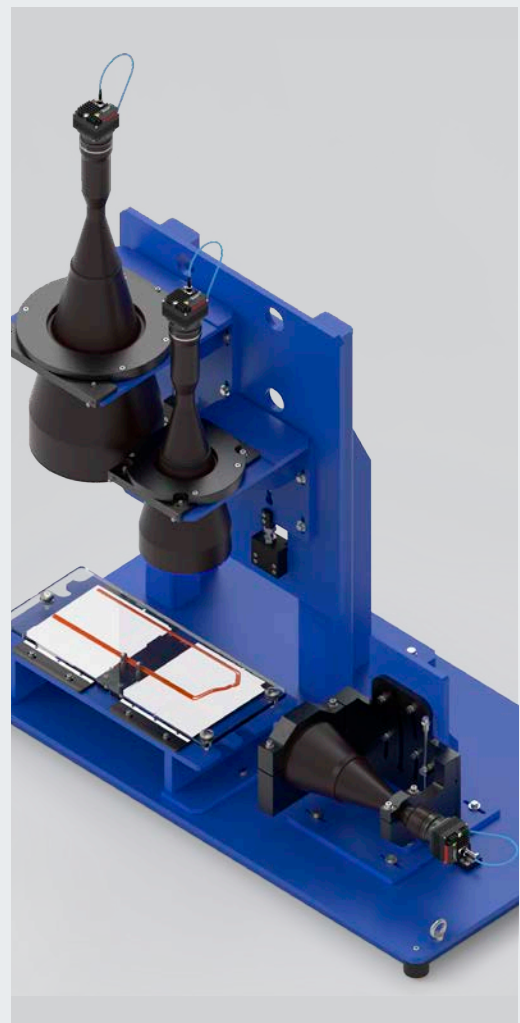

OPTICAL GAUGE FOR DIMENSIONAL CHECK

Dedicated off-line high performance optical solutions allow control of the hairpin bending process by checking the 2D geometry in real time. The measurement speed guaranteed by the optical technology also make this solution consistent with the line cadences for in-line applications.

The software tools analyze statistical data and correlate them with the metrology lab results for real quality assurance.



HAIRPINS

Research indicates that there are significant advantages in using flat wire hairpin windings on some types of motors. The main advantage is a much higher copper slot fill factor. This reduces heat and improves torque and power density, which ultimately can reduce the motor size for EV applications.

The hairpins have a flexible structure and individual shapes that differ in dimensions, angles and cross-section of copper. This is why geometry and quality of each one are crucial and so they should be checked in order to increase the quality assurance.

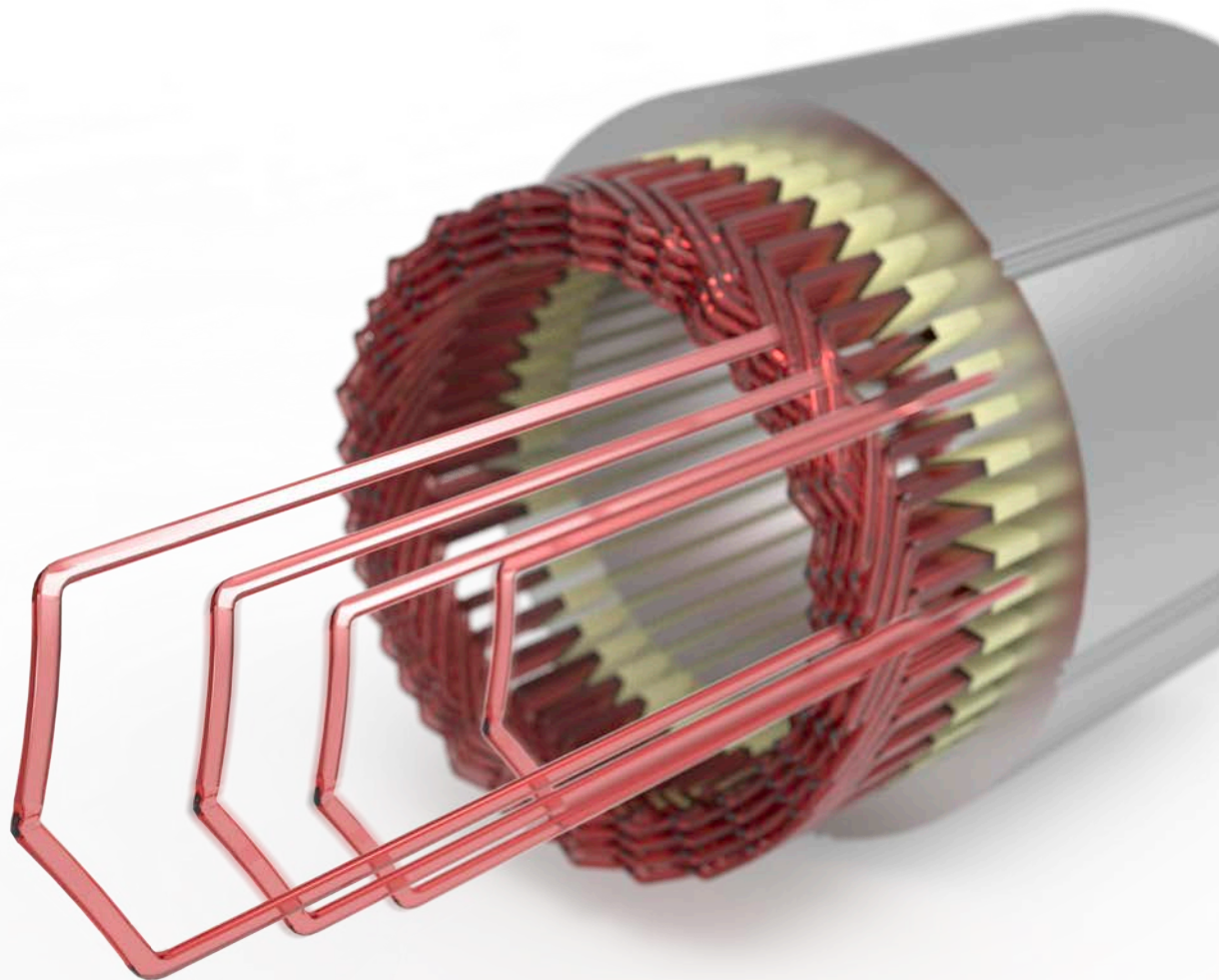

NON-CONTACT
GAUGING SOLUTIONS:
THE BEST CHOICE
FOR MEASUREMENT
OF FLEXIBLE
COMPONENTS



CUSTOMIZED SOLUTION FOR GAUGING AND INSPECTION

External diameter shape error generated during assembly of the cooling jacket with the stator can affect correct sealing of the housing assembly. Concentricity errors can affect the symmetry of the air gap between the rotor and stator.

Marposs can provide special gauging stations for checking internal and external diameters of the stator, as well as performing dynamic measurement of the external diameter concentricity with respect to the inner axis.

Optical solutions can be integrated for measurement and inspection of the hairpin terminals, before or after the welding operations.

ELECTRICAL TESTING OF STATORS

The insulating system of electric machines plays a fundamental role in the reliability of high voltage motors as insulation failure can result in a system breakdown. Since the insulation system of high voltage motors has a very complex nature, the high reliability of e-motors can only be achieved by performing different types of measures. Stator insulation quality assessment is an important issue, especially for e-motors powered by an inverter where its insulation is exposed to increased thermal/electrical stresses.

Marposs offers a wide range of testing solutions for in-line and off-line stator insulation quality verification. This includes intermediate testing prior to impregnation and final testing after impregnation, using standard high voltage tests (such as resistance insulation, Hi-Pot, Surge).

The same equipment can also integrate Partial Discharge testing, the only method that can identify latent insulation defects that could generate failures after a short operating time.

PARTIAL DISCHARGE
INSULATION TEST TO DETECT
LATENT DEFECTS – WHEN
CONVENTIONAL INSULATION
TESTS ARE NOT SUFFICIENT TO
GUARANTEE THE QUALITY OF
STATORS FOR USE
IN THE EV FIELD

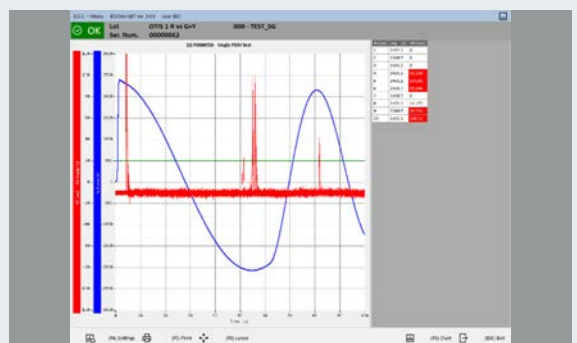



STATOR

The performance of an electric motor, in terms of power and efficiency, heavily depends on the stator quality. That's why all stator production steps should be checked in order to guarantee safety and reliability.

Whatever stator version is used, Marposs can propose several products and applications dedicated to the process control along the complete manufacturing chain, as well as solutions and machines for the quality check, the insulation and functional testing.

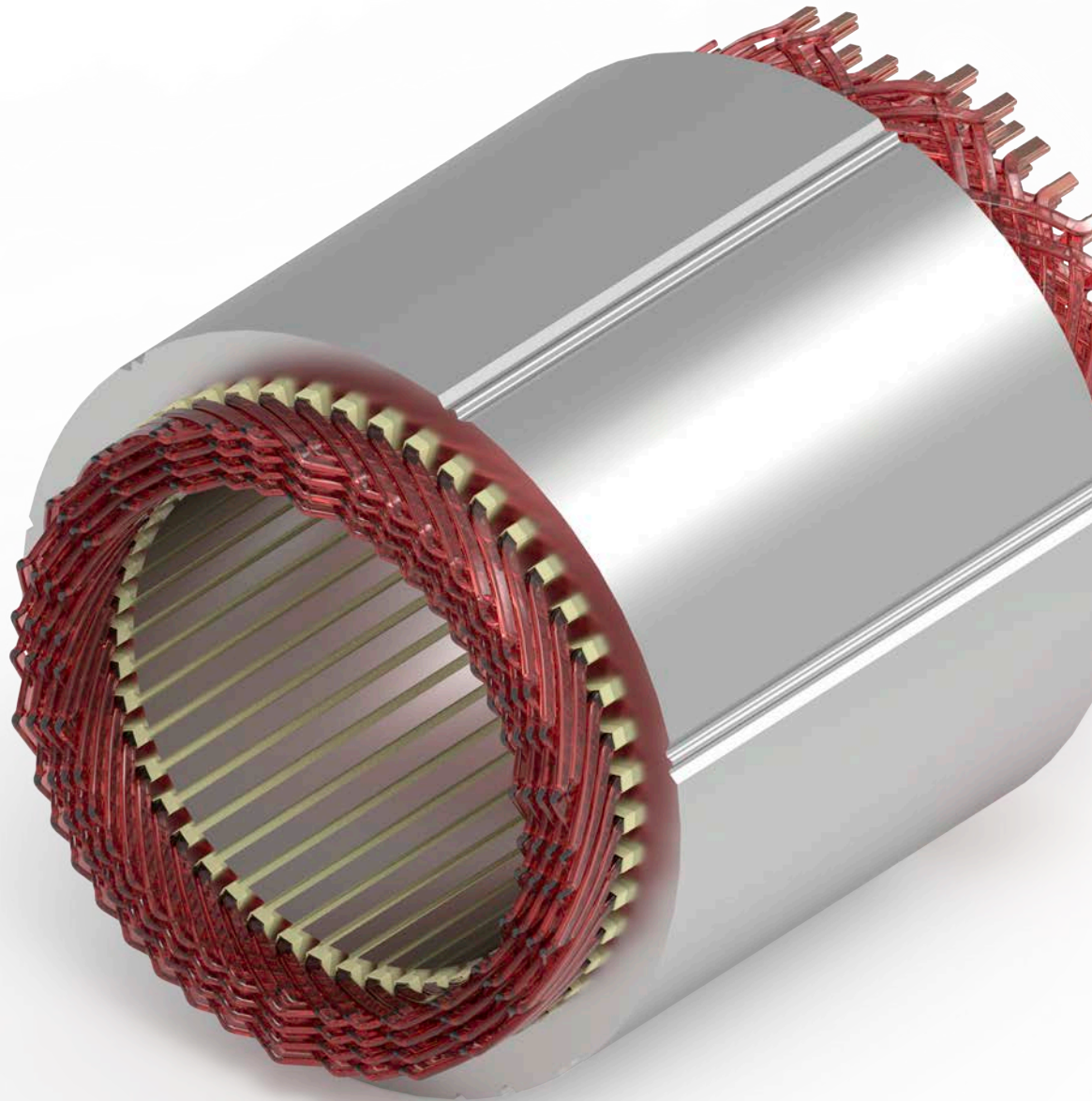

DIE CASTING PROCESS MONITORING - TTV

Most defects in the casting process, such as peeling, porosity, shrinkage and deposits, may be caused by a non-optimal distribution of the die temperature. TTV is an innovative infrared vision system designed to monitor the surface temperature of the die during the die casting process of light alloys by high pressure, low pressure or gravity. The thermal map is detected by the thermographic cameras installed in the machine. The images are always captured under the same processing conditions without interrupting the cycle, providing greater awareness of the process and how to optimize it.

PROCESS MONITORING IN METAL CUTTING OPERATIONS

The machining of metal parts can be monitored and documented by Marposs intelligent GENIOR MODULAR systems, including the condition of machine and cutting tools for process-related matters. This makes the process and current status visible and transparent, allowing monitoring within set limits. Captured sensor data allows analyses and prognoses for continuous improvement of production.

PROBING AND TOOL CHECKING IN METAL CUTTING OPERATIONS

Marposs high precision touch probes are successfully used to produce mechanical components for the EV sector. To accommodate increasingly stringent mechanical tolerances on precision machined components, Marposs probes, equipped with sensors, guarantee sub-micron precision in defining work pieces position. Marposs offers its expertise through the development of tailored measuring cycles that can identify, for example, virtual work-offset obtained by a cloud of points on a complex surface. Moreover, a complete set of measurement cycles helps operators to qualify the components after cutting process.

To achieve the most optimal process, Marposs offers a CCD camera-based Tool Setter that guarantees the highest accuracy and correlation among the entire set of tools. Tool setting on the machine automatically compensates for inevitable spindle thermal drift, avoiding adverse affects on the component dimensions.

“ DIE TEMPERATURE MONITORING TO CONTROL THE CASTING PROCESS AND PREVENT DEFECTS ”

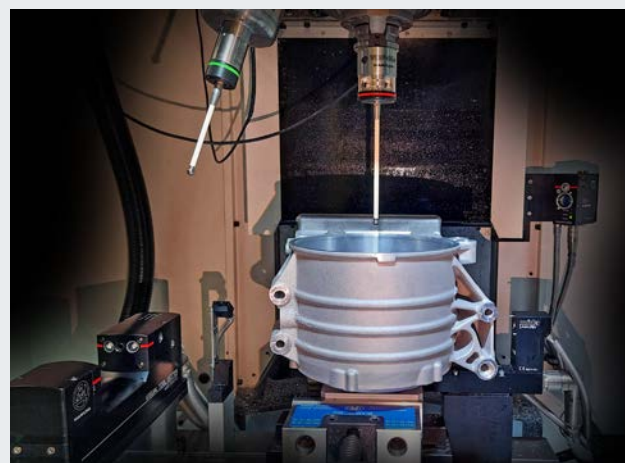



HOUSING

The electric motor, the inverter and the transmission group are increasingly located in the same housing, which is usually made in die cast aluminium and then machined by milling. Marposs thermographic analysis systems for process control during die casting operations are combined with traditional sensing, probing and in-process gauging solutions for process control during machining, turning and milling operations. The machine vision technique, based on Marposs 2D Mpixel high resolution camera, is able to detect defects and porosities on machined sealing surfaces that is essential to guarantee the perfect sealing between the housing parts.

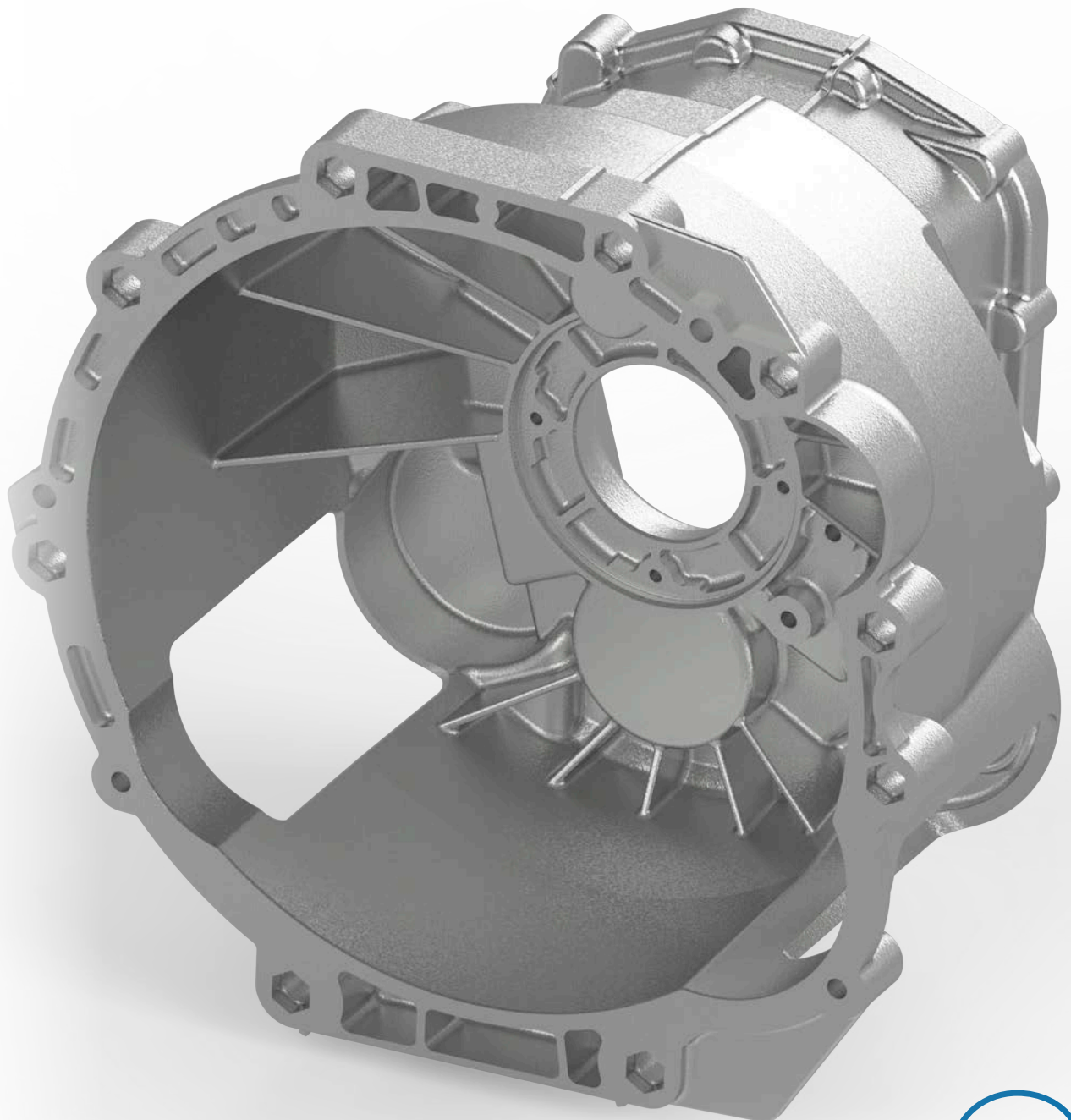

VISUAL INSPECTION OF THE SEALING SURFACES CAN BE ASSOCIATED TO FUNCTIONAL LEAK TESTING OF THE COMPONENTS TO GUARANTEE PERFECT SEALING OF THE ASSEMBLED PRODUCT

DIMENSIONAL GAUGING

Marposs provides a complete line of manual and automated solutions for dimensional gauging. The solutions are tailored according to each customer's needs and requirements, whether the quality control is for off-line sample-based measurement or integrated into automated production lines.

INSPECTION AND MACHINE VISION

Machine vision technology, based on a Marposs 20 Mpixel high resolution camera, combined with photometric stereo algorithms, allow detection of various defects such as porosities, scratches, or bumps on machined sealing surfaces of die-cast aluminium housings.

LEAK TESTING

Leak tests are performed to identify possible leaks due to material defects (porosity, blowholes, cracks), as well as issues related to the machining process or during assembly, identifying defective or missing parts, wrong positioning or assembly.

The presence of a leak could jeopardize the correct functioning of the component or its life span and can also be potentially dangerous for the environment and the safety of its user.

Marposs offers standard products or special solutions for leak testing and leak detection in the production of die cast housings and jackets, cooling circuits and complete e-motor assemblies. Different testing methods are available including pressure decay or mass flow methods, and helium tracing by sniffing technology as well as in an accumulation or vacuum chamber.

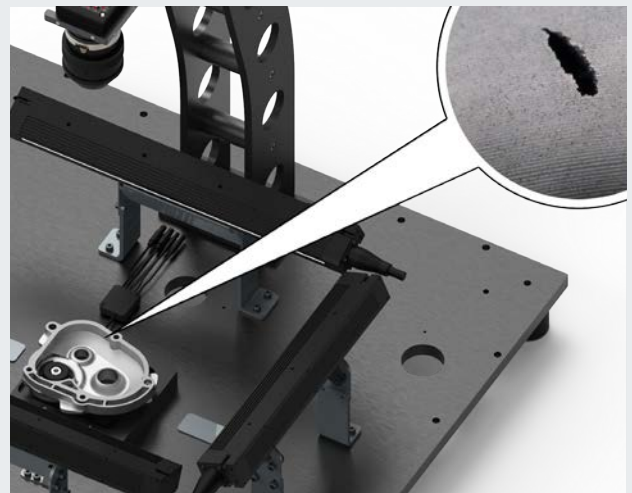



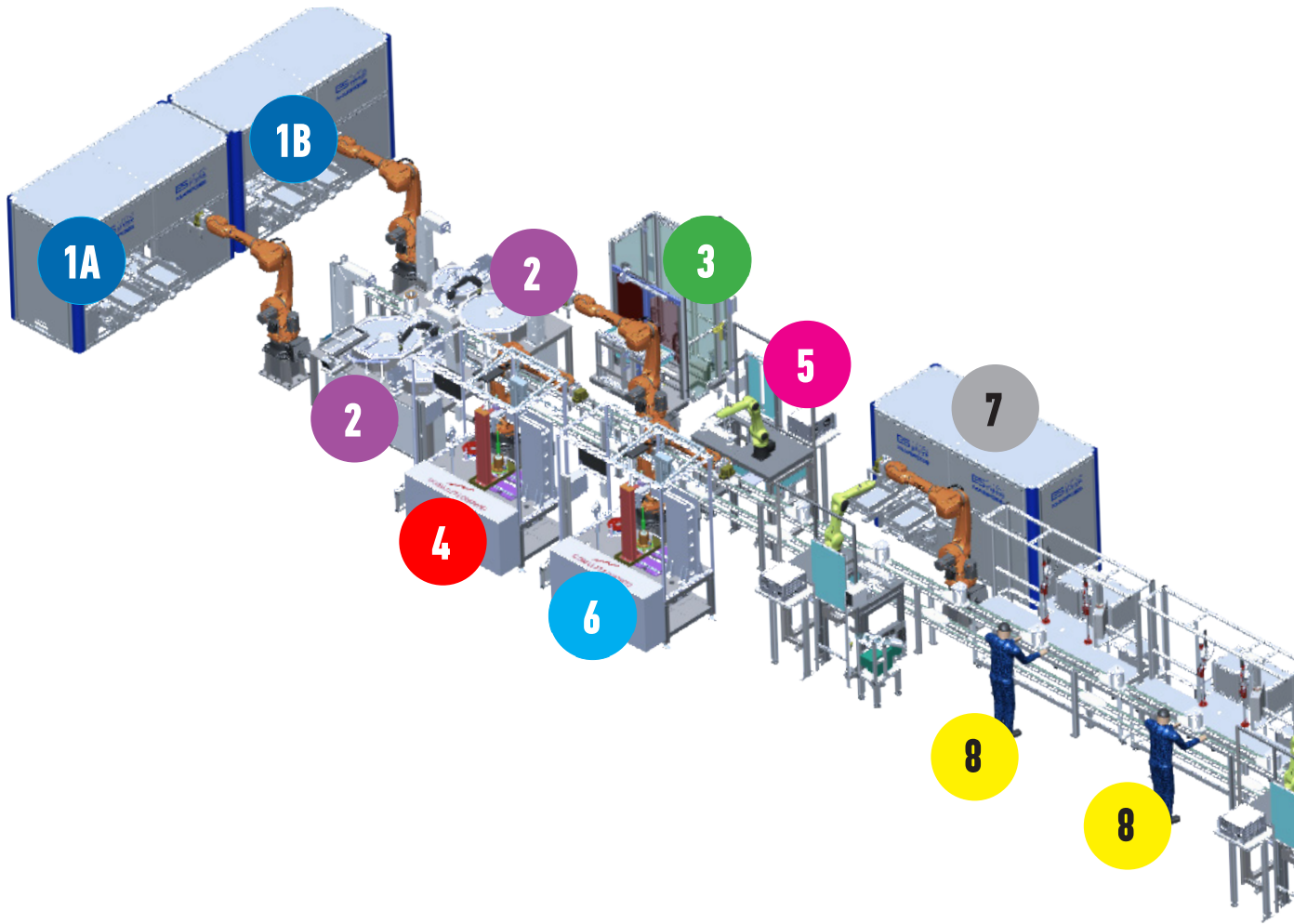

TEST BENCHES FOR ELECTRIC MOTORS:
LABORATORY SOLUTIONS FOR COMPLETE
CHARACTERIZATION IN THE PRODUCT
DEVELOPMENT PHASE

END-OF-LINE TESTING MACHINES FOR
QUALITY CONTROL IN PRODUCTION

- **1A** BASKET FEEDER: automatic system to feed the stators stored in baskets
- **4** PRESS: rotor/stator joining
- **1B** BASKET FEEDER: automatic system to feed the rotors stored in baskets
- **5** Screwing screws to the motor body
- **2** FLEXIFEED: bulk O-ring feeding
- **6** PRESS: frames joining to the motor
- **3** TRAY FEEDER: automatic system for the rear frame feeding
- **7** BASKET FEEDER: automatic system to feed the resolver stored in baskets
- **8** Manual station for electric wiring



ASSEMBLY AND FINAL TESTING

The efficiency of an electric motor depends on the choice of the materials used for the core and windings, on their physical arrangement and on the care and precision with which they are handled and assembled. The introduction of stresses in the magnetic steel during motor assembly can increase iron loss by up to 50%. Eccentricity between the stator and rotor generates harmonic fluxes with consequent higher losses. By paying attention to handling and assembling techniques, the losses can be reduced to negligible proportions.

Marposs can be a strategic partner in developing fully automatic assembly solutions for e-motors, as well as supporting the customers in phases of product co-design needed to ensure the in-line production is stable.

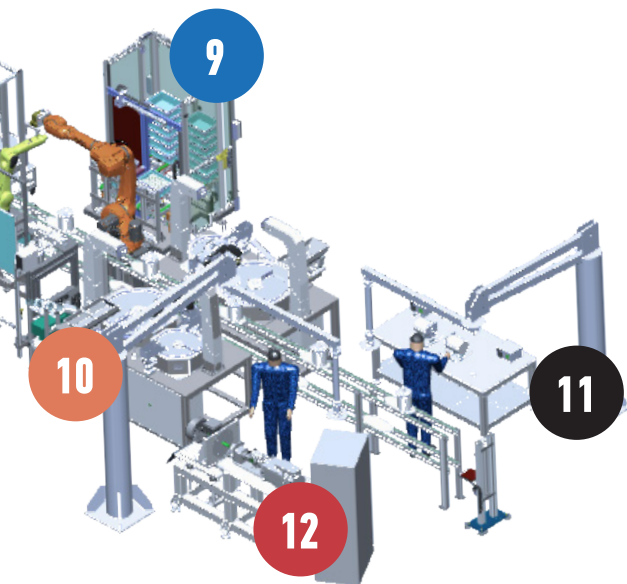

END-OF-LINE TESTING

Design-to-order test benches for End-of-Line testing of e-motors are typically based upon individual customer specification. Solutions for testing on automatic lines or for manual use, integrated or stand-alone, are available. Complete functional testing, including NVH analysis according to market standards, can be supplied. Customized dynamometer test benches designed for the complete assessment of electric motors in the laboratory environment can also be provided.

- 9** TRAY FEEDER: automatic system for the drive frames feeding
- 10** Screwing screws to the motor body
- 11** Final leakage test
- 12** Final electric test



LEADING-EDGE TECHNOLOGY IN GEAR INSPECTION, NVH ANALYSIS AND TRANSMISSION ASSEMBLY

GEAR CUTTING AND HOBBIING PROCESS MONITORING

The machining of gear parts requires high demands on gear hobbing tools and the process. The early detection of anomalies and process variations can be reliably detected with the GENIOR MODULAR system.

This allows an early intervention without faulty parts getting into the inspection process or into the assembly.

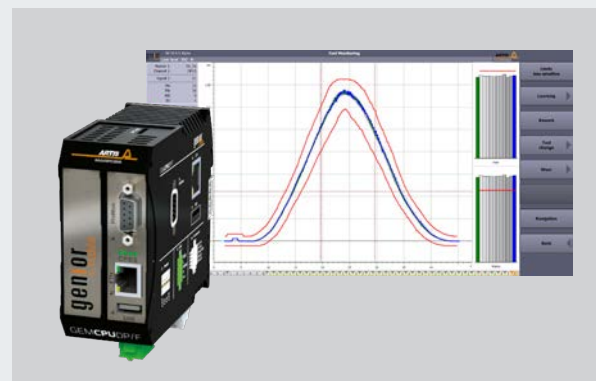

GEAR GRINDING AND WHEEL BALANCING

Energy efficiency is important in every sector, but crucial to the electromobility field in terms of extending car range.

The surface and shape quality of gears and mechanical components is a key to succeed in this technological evolution.

With Marposs Wheel Balancing and Acoustic Emissions cycles, the grinding wheel always operates optimally, maximizing production quality.



IN-LINE AND OFF-LINE DIMENSIONAL GEAR GAUGING

The working surfaces of gear teeth are often the result of several machining operations.

The surface texture imparted by the manufacturing process affects many of the gear's functional characteristics.

Thus, it is important to have a quality instrument for measuring the gear parameters after important machining operations, such as hobbing or teeth grinding.

M62 Flex is a flexible gauge suitable for the measurement of Diameter over Balls (MdK), Root Diameter and Major Diameter on external gears.

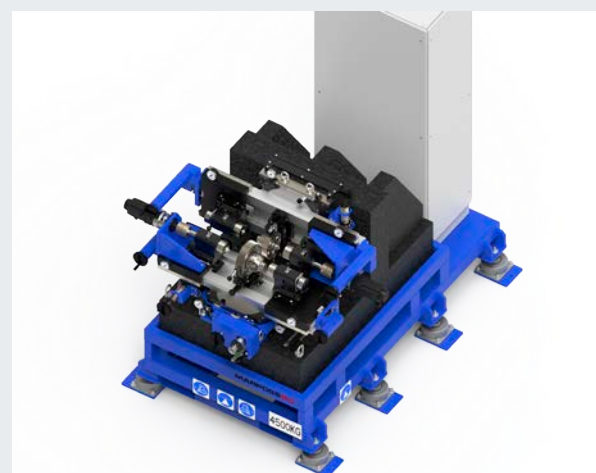

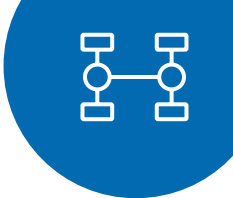

TRANSMISSION

The transmission of an electric vehicle is relatively simple given the electric motor's characteristics of high torque at low rotations and constant power during a large speed range. Typically, this is realized with only one or two speed ratios between input and output.

When designing a transmission, the high rotational speed associated with electric motors (up to 20,000 rpm) requires unique considerations in order to reduce power losses, ensure the highest efficiency and also control the noise generated. Noise is a major consideration in transmission design for electric vehicles as there is no engine noise to offset it as compared to internal combustion engines.

The tolerances of an electric vehicle transmission must be very tight. Special attention should be given to gear teeth geometry and mechanical design in terms of assembly and manufacturing in order to guarantee top quality and super performance.



“
THE NVH GEAR TESTER IS
THE OPTIMAL INSTRUMENT
TO IDENTIFY FAULTY AND
NOISY GEARS IN A TIMELY
MANNER
”

NVH TESTING OF INDIVIDUAL GEARS

Noise Vibration Harshness (NVH) analysis is a method of investigating the vibro-acoustical behaviour of a single component or of an assembly. Typically, this method is used to objectify the assessment of the vibrational behaviour of mechanical groups, especially due to mechanical power transmission.

Evaluating NVH on a component level can be more beneficial than analyzing the final assembly. This allows for the identification of defects (like macrogeometry errors) prior to assembly, when it might be too late to recover the whole assembly unit. Depending on the precision of the gearboxes, inspecting other items prior to assembly could be also recommended.



Basically, the concept of NVH testing is to stress the gears by applying rotation speeds and torque values similar (or even higher) to those that are applied in the real working conditions.

Thanks to the base structure of the machine made of granite, Marposs equipment is robust and stiff enough to become shock resistant to external disturbances and noise.

The gear (workpiece) that has to be inspected is meshed with a dedicated master gear in a configuration that is attributable to the Single Flank operating condition (the center distance is fixed).

The output parameter is the angular acceleration of the part (or master), evaluated instantaneously and in the long run with the use of encoders (TE inspection) and torsional accelerometer (TAC inspection).

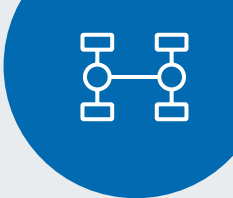

SINGLE FLANK AND TRANSMISSION ERROR ANALYSIS

The parts for a 2-speed or 1-speed gearbox must be manufactured with great precision to ensure that they do not cause any additional noise to the vehicle. The SF test is a rotational test of the manufactured gear with a master gear at their proper mounting position and with proper backlash, with one tooth flank in contact while optical encoders measure the angular displacement relative to a perfect gear. Marposs M62 SF test includes the collection of transmission error data and noise analysis.

Marposs has also developed one special Single Flank system to use in the Laboratory to test prototype parts with the purpose of providing feedback to the gear design process. The system has the capability of testing either part vs master gear or part vs the mating gear as in the real transmission (reducer). The operator even has the ability to adjust both center distance and angle of inclination of the axis in order to obtain the configuration leading to the minimum noise contribution.

FUNCTIONAL GEAR TESTING

M62 Double Flank bench gauge, for external and internal gears, is suitable for checking the composite deviation of gears, with capability to expand upon the traditional functional parameters operating with no backlash (double flank rolling action). The gear under inspection is meshed to a rolling artifact (master) manufactured according to a more stringent quality grade.

NCG ON GEARS

The high precision of e-Drive gears often requires the use of non-contact technology for the inspection of some parameters.

Marposs can provide solutions using laser scan sensor or chromatic confocal technology to measure features such as the size of chamfers and flank profile.

SHIM SELECTIVE ASSEMBLY

The process of assembling a high-speed gearbox normally requires the determination and verification of the correct shims for the assembly in order to prevent any issue that may lead to noise or to the incorrect functioning of the transmission.

The selective shim assembly process is mainly performed either for adjusting the preload of a set of tapered bearings or for adjusting the backlash of a pair of mating gears.

When it comes to electrified transmissions, which are subjected to several challenges and requirements, the integration of a measuring system to make the above-mentioned operations becomes essential.

LEAK TESTING

Marposs offers tailor-made leak testing solutions for gear box transmission housings to fit all the requirements of the industry including manual or fully automatic machines with a wide range of available options.

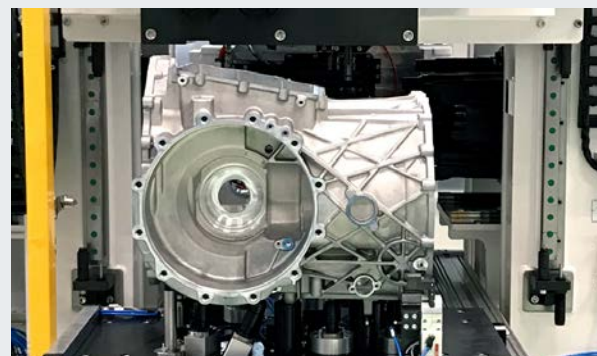

LEAK TESTING

Marposs' strong experience in leak testing applications and ability to integrate different technologies guarantee the best solution for verifying the integrity of electrical powertrain components, such as electric motors, power electronics and related cooling circuits. Dedicated solutions meet different customer needs, from a simple manual station to automatic systems integrated into production lines.

ASSEMBLY

Marposs provides flexible solutions for the complete assembly of electro-mechanical components, such as inverters and battery chargers. Depending on customer specifications, different assembly solutions - including manual or fully automatic operations - are combined with measurement and test systems, including complete end-of-line functional verification.

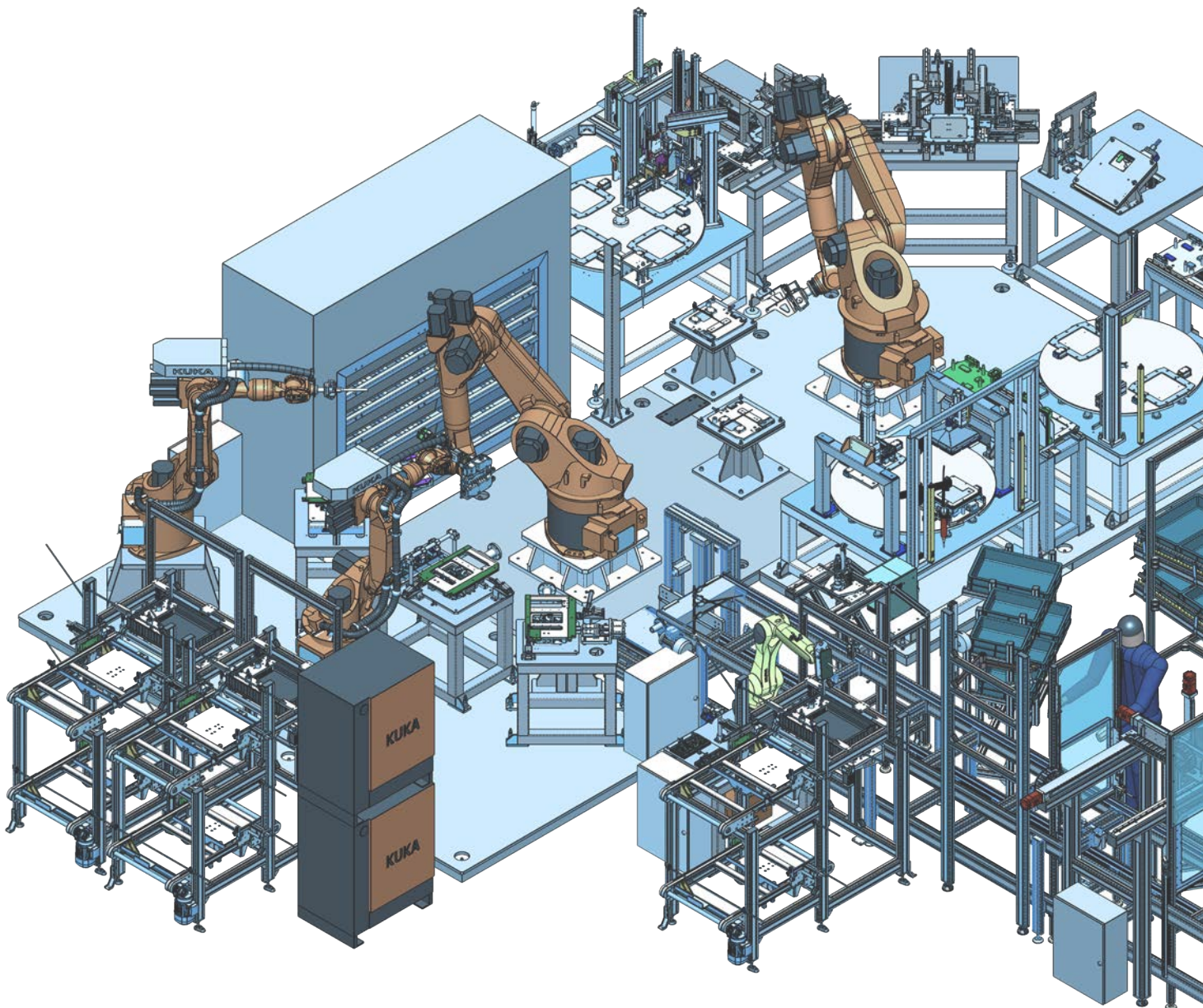

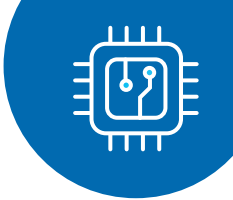

POWER ELECTRONICS

In the automotive industry, power electronics include devices such as inverter and battery charger, which control the conversion of electric power operated by solid-state electronics.

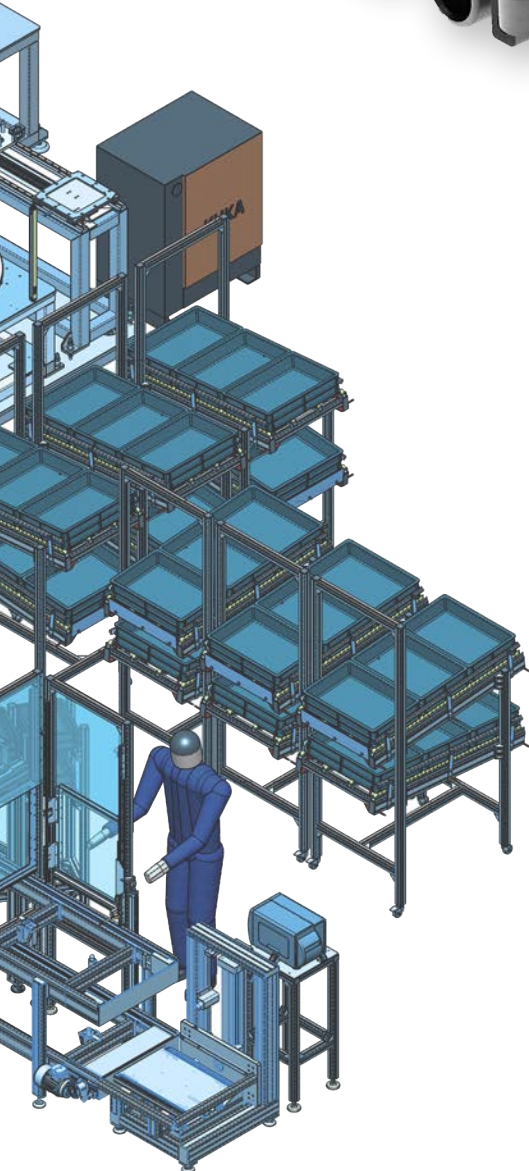
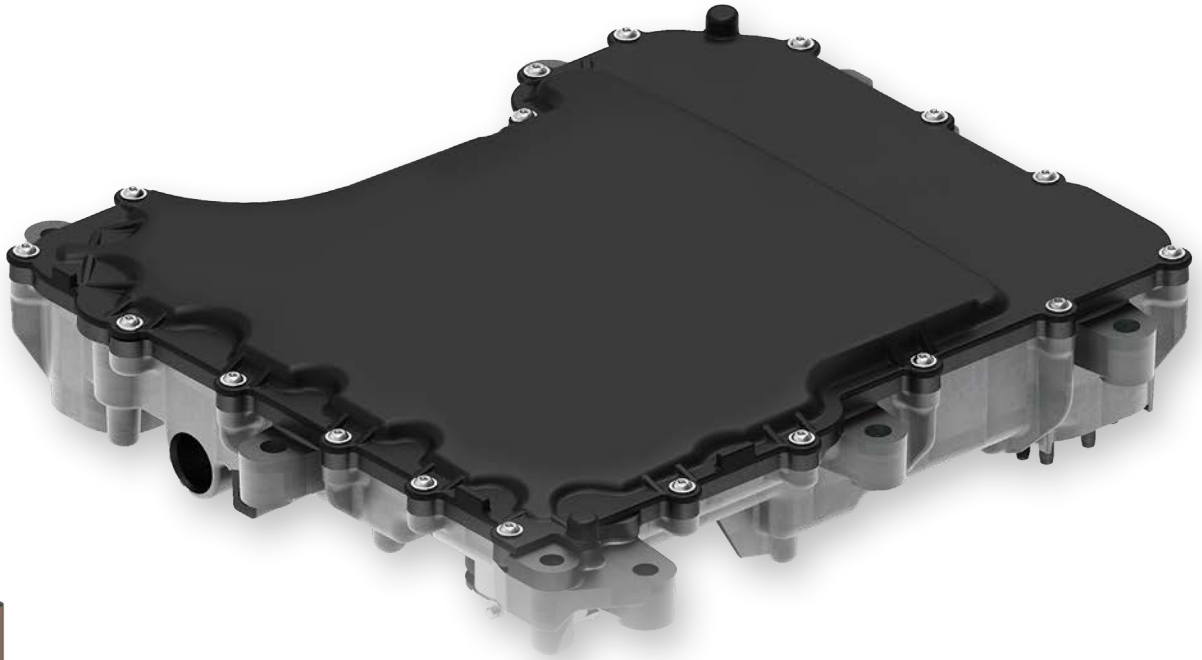



MARPOSS

For a full list of address locations, please consult the Marposs official website

Edition 07/2021 - Specifications are subject to modifications © Copyright 2021 MARPOSS S.p.A. (Italy) - All rights reserved.

MARPOSS, logo and Marposs product names/signs mentioned or shown herein are registered trademarks or trademarks of Marposs in the United States and other countries. The rights, if any, of third parties on trademarks or registered trademarks mentioned in the present publication are acknowledged to the respective owners.

Marposs has an integrated system to manage the Company quality, the environment and safety, attested by ISO 9001, ISO 14001 and OHSAS 18001 certifications.