

AEROEL QUADRALINE^{XY}

Laser system for in-line control of rolled or extruded products featuring rectangular cross section

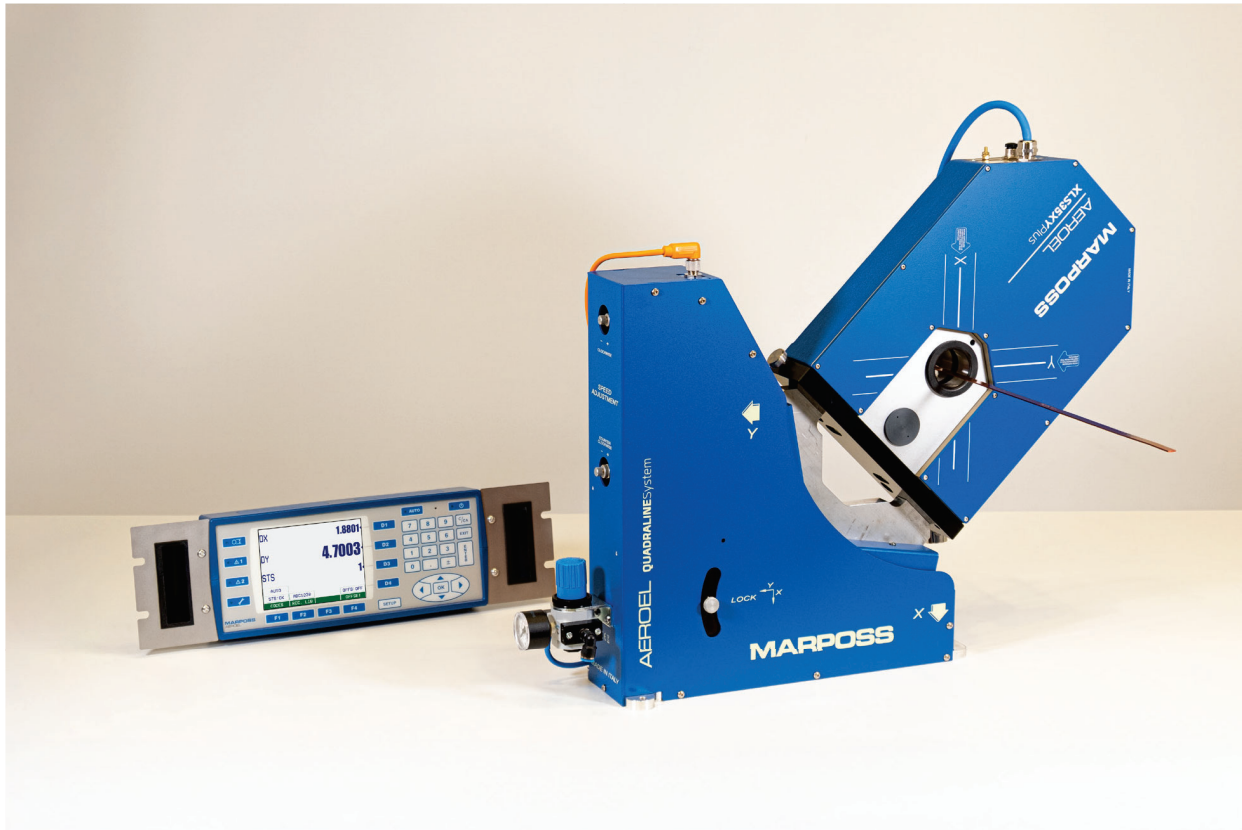

Quadriline.XY is a laser system designed to control the 2 dimensions, height (H) and width (W) of extruded or rolled products featuring rectangle-like cross section, such as flat wire hairpin, superconductors, metal straps, plastic or metal section, etc.

The main functions of the system are as follows:

- Measurement and display of the 2 external dimensions, height (H) and width (W)
- Generation of out-of-tolerance alarms
- Automatic process regulation, with 2 independent channels
- Processing and printing of statistical reports
- Interface with remote computer

MARPOSS

HOW DOES IT WORK ?

The Quadraline.XY system is based on an dual-axis laser gauge installed on-line, which measures the external dimensions of the product along 2 directions at 90°. In such a way it is possible to measure both the height and the width, provided that the measuring directions be aligned along the axes of the rectangular cross section of the product. In addition, to avoid that small and random twisting of the product around its axis may affect the gauging accuracy, a special filtering software saves and processes only the minimum values of the readings for each axis: these are exactly the true dimensions being gauged. Should it be impossible to keep the product alignment, it is possible to mount the gauge on a special oscillating fixture ($\pm 5^\circ$ max.) to guarantee that the two minimum values corresponding to the section dimension are always detected, whatever is the orientation of the product section. The fixture is powered by standard compressed air and the cycle time and the span angle can easily adjusted by the operator; a limit switch provides the synchronisation between the measuring period and the oscillation cycle

The signals from the laser gauge are processed by the software which constantly compares the measured values with the nominal set-points entered by the operator. If the actual dimensions of the product tend to go outside the pre-set limits, the software automatically corrects the machine, to keep the product in tolerance.

When working on rolling machines, 2 independent feedback loops are available, to adjust the distance between the rolls pairs that drive H and W dimensions. The results of measurement during manufacturing can be stored in memory and processed to produce the fully-detailed statistical reports required for quality certification.

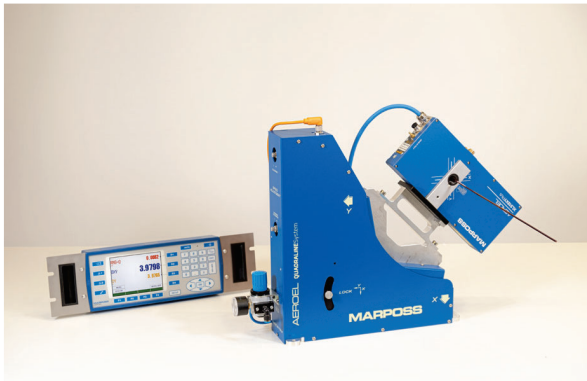

SYSTEM CONFIGURATION

The Quadraline.XY system uses dual-axis Xactum Laser Gauges.

The Basic system is composed of:

- XLS13XY or XLS35XY Xactum Laser Gauge;
- CE-200, Operator's Interface Panel, 19" Rack mount version;
- Quadraline.XY software (basic module) pre-installed in the Gauge
- 5 m long connecting cable

Some options and accessories available to complete the system are:

- Oscillating fixture to mount the gauge
- Supplementary software for machine regulation and/or statistical reporting;
- Electronic and/or motor driven potentiometer for interface with the machine;
- Proximity switch for length counting;
- Telescopic stand for laser gauge;
- Protective bracket for the gauge with pressurizing facility;
- High pressure centrifugal blower;
- Extension cables.

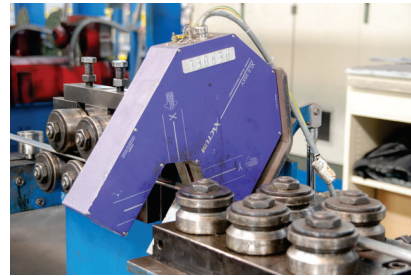

ADVANTAGES

Laser technology makes possible **non-contact measurement**, to gauge moving products, hot or soft, when contact probes are ineffective.

On-line application allows **100% tolerance check**.

Running close to the lower tolerance limit means significant **material savings**.

The automatic process control **reduces manning requirements**.

Improvement in quality and **reduction of waste**.

Product quality and process capability can be proven by **printed reports**.

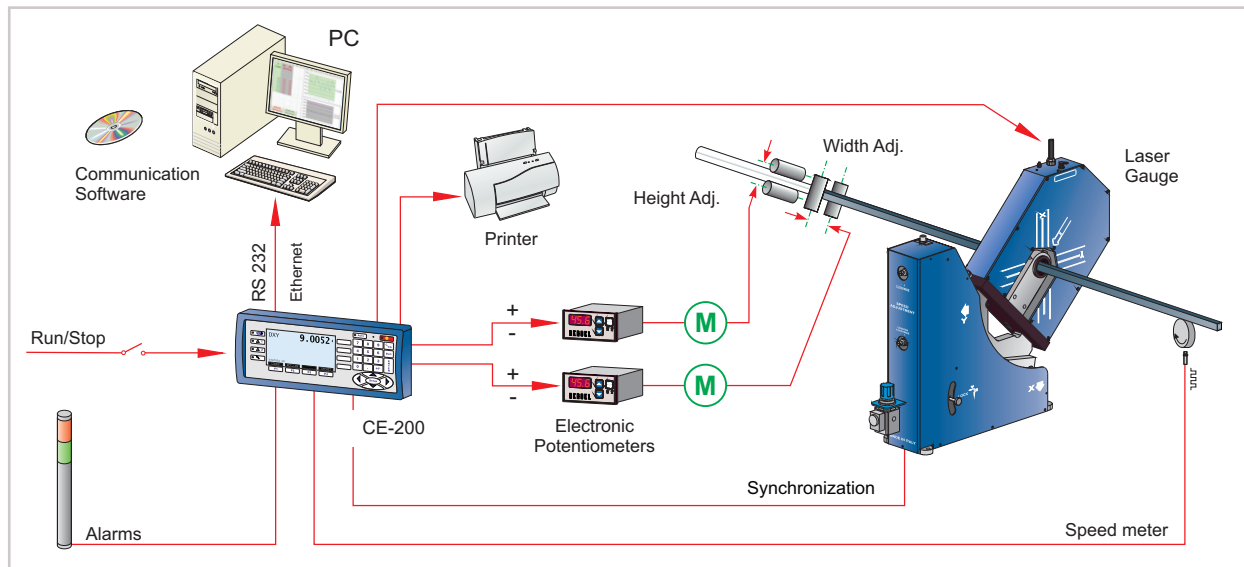

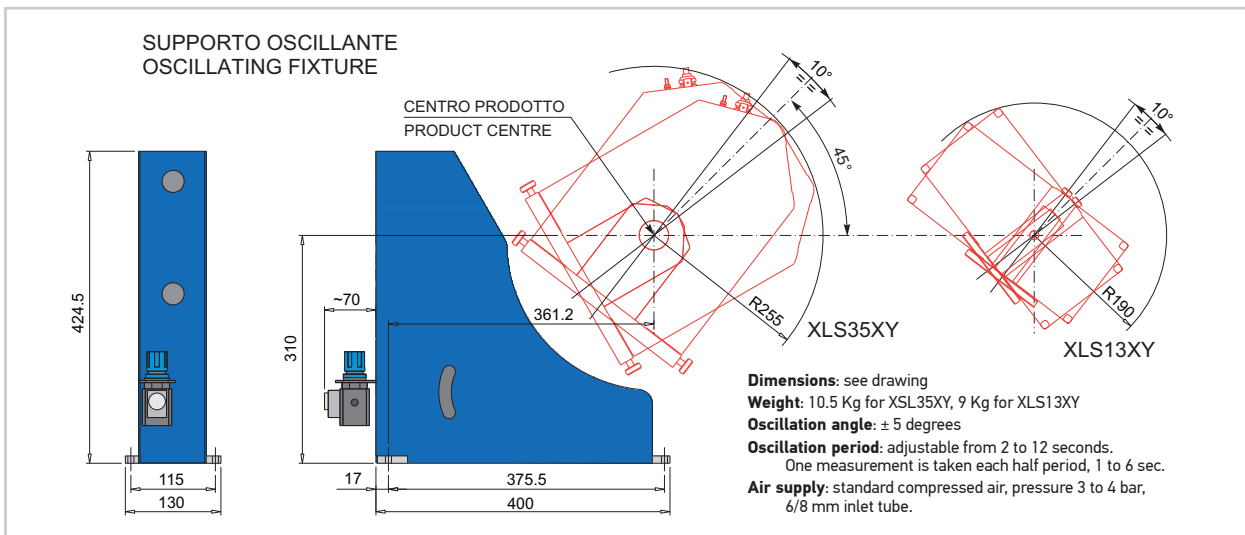

THE QUADRALINE.XY SOFTWARE

The Quadraline.XY software is pre-loaded inside the Xactum gauge and, thanks to its modular structure (basic package + optional Regulation and Statistics) it can meet all operational requirements. Special care has been taken to ensure that the system is easy to use and simple to program even by non-experts. Through the CE-200 Interface Panel, the operator uses function keys and pop-up menus to select the various functions or to enter the numerical values requested by the program.

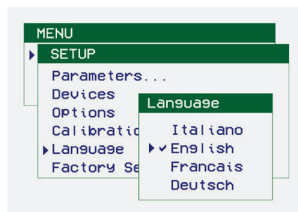

The basic package includes the following functions:

- Measurement of the minimum or maximum values along X(H) and Y(W) axes.
- Automatic synchronization with the oscillating fixture
- Display of the measured values and of the shift from the nominal set-points.
- 3 measured values can be simultaneously displayed on the screen.
- Programmable alarms and pre-alarms for out-of-tolerance conditions.
- Measurement of opaque or transparent products (Glass Logic).
- Library of parameters for 1000 different products, directly retrievable by the operator.
- Possibility of entering a password to restrict the programming functions to authorized personnel.
- Ethernet / Rs232 interface for remote programming or data retrieval.
- Multi-lingual menus (Italian, English, French and German).
- Selectable measuring unit (mm or inches) and resolution.
- Pre-programmed factory set-up to facilitate installation and start-up of the system.

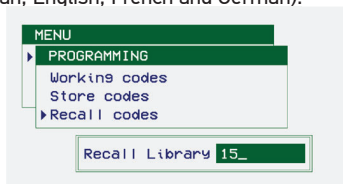

The additional Process Regulation module (Option 1) features the following functions:

- Software for automatic regulation of the product dimensions, by adjusting the line speed or the distance between the rolling rolls.
- Two independent regulation channels are driven, for H and W dimensions.
- PI (Proportional Integral) mode using INC (+) or DEC (-) pulses.
- The regulation takes place only when a tendency to deviate from the nominal set-point is positively verified.
- Automatic compensation of dead time according to variations of line speed.
- Control parameters can be programmed and stored in the product library.
- Programmable hot/cold offset to compensate for the thermal expansion of the extruded product when measurement is performed immediately after the extrusion head.

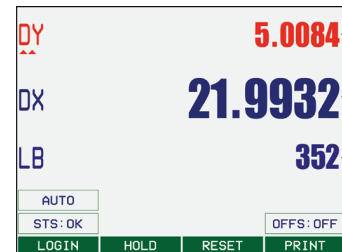

The additional Statistics module (Option 2) offers the following functions:

- Histograms showing the H and the W values, measured during the manufacturing.
- Programmable limits for the exclusion of any abnormal measurement value arising from anomalous working conditions.
- The data acquisition interval can be selected manually by the operator or determined automatically via a Start/Stop input signal.
- Recording of maximum, minimum and average values.
- Calculation of standard deviation and Cp and Cpk factors.
- Total length and average speed reporting.
- All listings show the date and time
- Identification of the operator, the machine and the type of product.
- Progressive numbering of the reel.

SPECIFICATIONS

XLS13XY

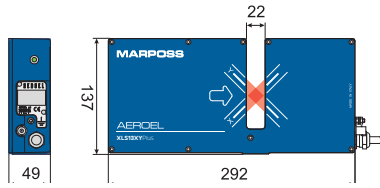

XLS35XY

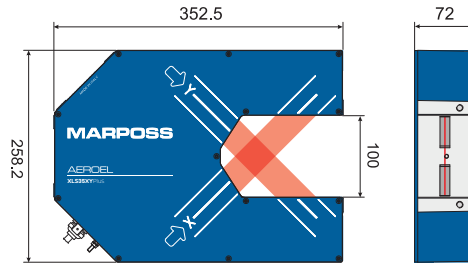

All dimensions are in mm.

	QUADRALINE. XY13	QUADRALINE. XY35
Gauge Model	XLS13XY/1500/B	XLS35XY/1500/B
Measuring Field (mm)	13 x 13	35 x 35
Measurable Dimensions (mm)	0.1 - 4	0.3 - 30
Resolution (Selectable) (µm)	10 / 1 / 0.1 / 0.01	
Repeatability (T=1s, ±2σ) ⁽¹⁾ (µm)	± 0.75	± 1.25
Linearity (Centred Product) ⁽²⁾ (µm)	≤ ± 5	≤ ± 10
Scanning Rate (Hz)	1500 (X) x 1500 (Y)	
Laser Source	VLD (Visible Laser Diode); λ = 650 nm	
Operating Temperature Range (°C)	0 - 50	
Thermal Coefficient ⁽³⁾ (µm/m°C)	- 11.5	
Dimensions (gauge only) (mm)	292 x 137 x 49	352.5 x 258.2 x 72
Weight (gauge only) (kg)	2.5	5.8

Notes

- (1) Specified with averages of four scans and oscillation half-period of 1s.
- (2) Maximum error when measuring flat surfaces, due to possible reflections on the product surfaces. The error value depends upon the dimensions of the section and it is a constant value for each product. A programmable "offset" value for each product can be stored in the memory, to compensate and cancel this error.
- (3) Typical value. It states the measurement drift due to the room temperature change, when measuring a master with null coefficient of expansion (INVAR).

Specifications of the gauge when used for the QUADRALINE Systems; for further details check the technical data-sheets and our web site.

Specifications subject to change without notice. For additional details and complete specifications please see the gauge data sheet.

CE-200 Operator's Interface Panel



Color **LCD Display**, 640x480, backlit
 "Touch-Sensitive" **capacitive keyboard**, with 35 keys and 7 warning LED
RS485 interface to connect the XLS gauges
8 protected PNP outputs, **5 PNP inputs**, **2 inputs** to the gauge
Ethernet & RS232 ports and **Centronics output** for parallel printer
2 configurable analog outputs
Dimensions: 132 x 350 x 76.5 mm (panel alone)
Weight: 2 kg (panel), 2,8 kg (Rack mounting version)
Power supply: 24 VDC, 100 mA Typical (1 A max)

Electronic potentiometer



Analog output from **0 to 10 Volt**, adjusted by INC (+) or DEC (-) pulses.
Additional PWM output to drive solenoid valve
Output level display in % of range, 3 digits LED display H=14,2 mm
LOCAL or REMOTE adjustment mode.
Memory of last setting before power down.
Plastic case DIN43700
Dimensions: 96 x 48 x 106 mm
Power supply: 24 VDC/VAC, 100 mA

