

ADS-31 PIEZOELECTRIC STRAIN SENSOR

Properties

- Suitable for all ARTIS monitoring systems
- Integrated piezo load amplifier
- High sensitivity
- One-dimensional measuring direction
- Easy mounting
- Sensor cable can be laid easily in the machine
- Resistant PUR-sheet



Illustration similar

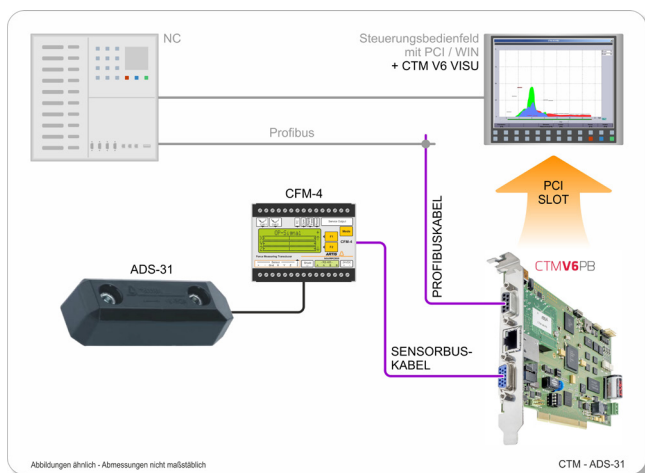
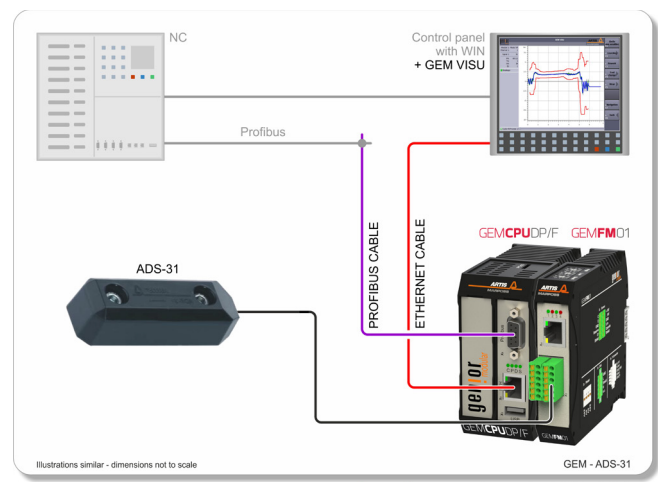
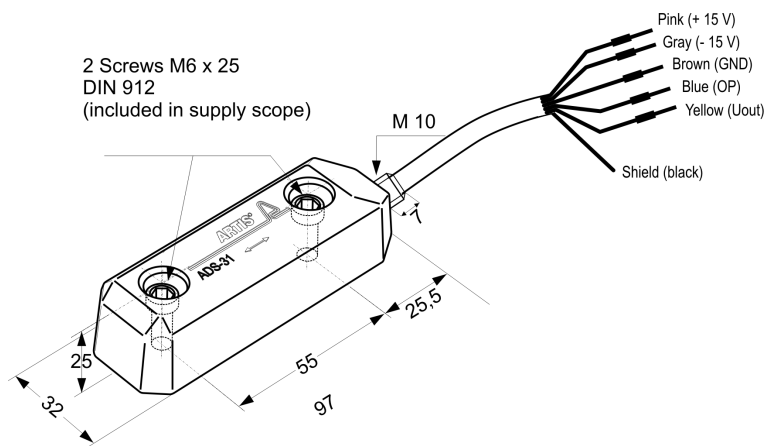

Illustration similar

Application example:
ADS-31 and **CFM-4** measuring transducer with the **CTM Tool** and **Process Monitoring System**.



Application example:
ADS-31 and **GEMFM01** force measuring transducer with the **GENIOR MODULAR Tool** and **Process Monitoring System**.



ARTICLE NUMBER	
CODE	O3PZ021100x (x = see variants)
VARIANTS	
ADS-31, 5 M CABLE	O3PZ0211007
ADS-31, 15 M CABLE	O3PZ0211008
ADS-31, 25 M CABLE	O3PZ0211009

DIMENSIONS	see drawing
WEIGHT	
ADS-31, 5 M CABLE	0.432 kg
ADS-31, 15 M CABLE	0.868 kg
ADS-31, 25 M CABLE	1.261 kg
MATERIAL	
INNER PART	Chromium nickel steel
SHEAT	PUR-sheat, resistant to cooling lubricants
DEGREE OF PROTECTION	IP66/IPx7 resistant to cooling lubricants
OPERATING TEMPERATURE	10 °C ... +50 °C

CABLE LENGTHS	see variant
WIRE BREAK DETECTION	in the dedicated measuring transducer
MEASURING SECTION	55 mm
VOLTAGE SUPPLY	-15 V DC / 0 V / +15 V DC
OUTPUT SIGNAL	± 10 V
ACTIVATION	+5 V DC
CONFORMITY	CE, UKCA

PU CABLE	
CABLE TYPE	PU cable, suitable for drag chains
DIAMETER	6 mm
CONDUCTOR SIZE	(AWG 26)
BENDING RADIUS	7.5 x cable diameter
WIRE CONFIGURATION	Conductor, fine wired acc. to VDE 0295



www.marposs.com

For a full list of address locations, please consult the Marposs official website

ODN6403EN01 – Edition 04/2022 – Specifications are subject to modifications
© Copyright 2010-2022 MARPOSS S.p.A. (Italy) – All rights reserved.

MARPOSS,  and Marposs product names/signs mentioned or shown herein are registered trademarks or trademarks of Marposs in the United States and other countries. The rights, if any, of third parties on trademarks or registered trademarks mentioned in this publication are acknowledged to the respective owners.

Marposs has an integrated system for Company quality, environmental and safety management, with ISO 9001, ISO 14001 and OHSAS 18001 certification.



Download the latest version of this document

